



N-Channel Enhancement Mode MOSFET

Features

- 30V/120A,
 $R_{DS(ON)}=2.2m\Omega$ (Typ.) @ $V_{GS}=10V$
 $R_{DS(ON)}=3m\Omega$ (Typ.) @ $V_{GS}=4.5V$
- Reliable and Rugged
- Lower Q_g and Q_{gd} for high-speed switching
- Lower $R_{DS(ON)}$ to Minimize Conduction Losses
- 100% UIS + R_g Tested
- ESD protection
- Lead Free and Green Devices Available
(RoHS Compliant)

Applications

- Power Management in Desktop Computer or DC/DC Converters.
- Power Load Switch.
- Notebook Battery Management.

Pin Description

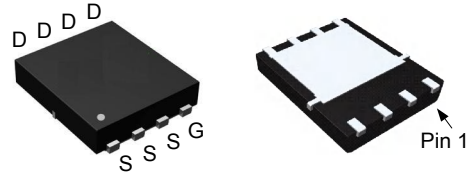

DFN5x6 8L EP1_P

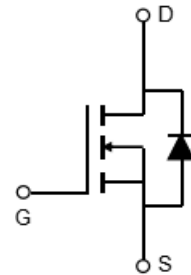

N-Channel MOSFET

**Absolute Maximum Ratings** ($T_A = 25^\circ\text{C}$ Unless Otherwise Noted)

Symbol	Parameter	Rating	Unit
Common Ratings			
V_{DSS}	Drain-Source Voltage	30	V
V_{GSS}	Gate-Source Voltage	± 20	
T_J	Maximum Junction Temperature	150	$^\circ\text{C}$
T_{STG}	Storage Temperature Range	-55 to 150	
I_S	Diode Continuous Forward Current	$T_C=25^\circ\text{C}$ 31	A
I_D	Continuous Drain Current	$T_C=25^\circ\text{C}$ 120	
		$T_C=100^\circ\text{C}$ 74	
P_D	Maximum Power Dissipation	$T_C=25^\circ\text{C}$ 56	W
		$T_C=100^\circ\text{C}$ 22	
$R_{\theta JC}$	Thermal Resistance-Junction to Case	Steady State	$^\circ\text{C/W}$
I_S	Diode Continuous Forward Current	$T_A=25^\circ\text{C}$ 1.9	A
I_D^a	Continuous Drain Current	$T_A=25^\circ\text{C}$ 22.8	
		$T_A=70^\circ\text{C}$ 18.2	
I_{DM}^b	Pulsed Drain Current	$T_A=25^\circ\text{C}$ 92	
P_D^a	Maximum Power Dissipation	$T_A=25^\circ\text{C}$ 2.08	W
		$T_A=70^\circ\text{C}$ 1.33	
$R_{\theta JA}$	Thermal Resistance-Junction to Ambient	$t \leq 10\text{s}$ 20	$^\circ\text{C/W}$
		Steady State 60 ^a	
I_{AS}^c	Avalanche Current, Single pulse	$L=0.1\text{mH}$ 80	A
E_{AS}^c	Avalanche Energy, Single pulse	$L=0.1\text{mH}$ 320	mJ

Note a : Surface Mounted on 1in^2 pad area, $t \leq 10\text{sec}$. $R_{\theta JA}$ steady state $t=999\text{s}$.

Note b : Pulse width is limited by max. junction temperature.

Note c : UIS tested and pulse width limited by maximum junction temperature 150°C (initial temperature $T_J=25^\circ\text{C}$).

**Electrical Characteristics** ($T_A = 25^\circ\text{C}$ unless otherwise noted)

Symbol	Parameter	Test Conditions	Min.	Typ.	Max.	Unit
Static Characteristics						
BV_{DSS}	Drain-Source Breakdown Voltage	$V_{GS}=0V, I_{DS}=250\mu A$	30	-	-	V
$BV_{DSS(t)}$	Drain-Source Breakdown Voltage (transient)	$V_{GS}=0V, I_{D(aval)}=36A$ $T_{case}=25^\circ\text{C}, t_{transient}=100ns$	34	-	-	V
I_{DSS}	Zero Gate Voltage Drain Current	$V_{DS}=24V, V_{GS}=0V$	-	-	1	μA
		$T_J=85^\circ\text{C}$	-	-	30	
$V_{GS(th)}$	Gate Threshold Voltage	$V_{DS}=V_{GS}, I_{DS}=250\mu A$	1.4	1.7	2.5	V
I_{GSS}	Gate Leakage Current	$V_{GS}=\pm 20V, V_{DS}=0V$	-	-	± 12	μA
$R_{DS(ON)}^d$	Drain-Source On-state Resistance	$V_{GS}=10V, I_{DS}=20A$	-	2.2	3	$m\Omega$
		$T_J=125^\circ\text{C}$	-	2.2	-	
		$V_{GS}=4.5V, I_{DS}=15A$	-	3	4	
Gfs	Forward Transconductance	$V_{DS}=5V, I_{DS}=15A$	-	30	-	S
Diode Characteristics						
V_{SD}^d	Diode Forward Voltage	$I_{SD}=20A, V_{GS}=0V$	-	0.8	1.1	V
t_{rr}	Reverse Recovery Time	$I_{SD}=5A, dI_{SD}/dt=100A/\mu s$	-	39	-	ns
t_a	Charge Time		-	23	-	
t_b	Discharge Time		-	16	-	
Q_{rr}	Reverse Recovery Charge		-	33	-	
Dynamic Characteristics						
R_G	Gate Resistance	$V_{GS}=0V, V_{DS}=0V, F=1MHz$	-	0.9	2.1	Ω
C_{iss}	Input Capacitance	$V_{GS}=0V,$ $V_{DS}=15V,$ Frequency=1.0MHz	-	1860	2400	pF
C_{oss}	Output Capacitance		-	1220	1586	
C_{rss}	Reverse Transfer Capacitance		-	92	120	
$t_{d(ON)}$	Turn-on Delay Time	$V_{DD}=15V, R_L=15\Omega,$ $I_{DS}=1A, V_{GEN}=10V,$ $R_G=6\Omega$	-	15	-	ns
t_r	Turn-on Rise Time		-	8	-	
$t_{d(OFF)}$	Turn-off Delay Time		-	38	-	
t_f	Turn-off Fall Time		-	54	-	
Gate Charge Characteristics						
Q_g	Total Gate Charge	$V_{DS}=15V, V_{GS}=10V,$ $I_{DS}=20A$	-	30	45	nC
Q_g	Total Gate Charge	$V_{DS}=15V, V_{GS}=4.5V,$ $I_{DS}=20A$	-	14	-	
Q_{gth}	Threshold Gate Charge		-	3	-	
Q_{gs}	Gate-Source Charge		-	5.3	-	
Q_{gd}	Gate-Drain Charge		-	3.6	-	

Note d : Pulse test ; pulse width $\leq 300\mu s$, duty cycle $\leq 2\%$.



Typical Operating Characteristics

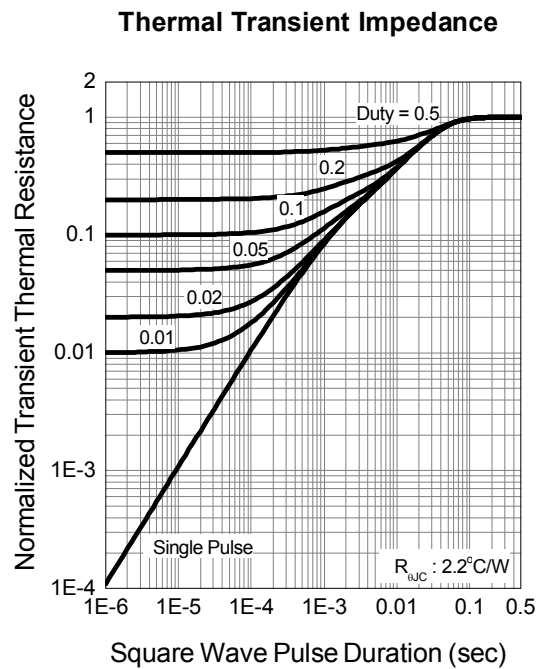
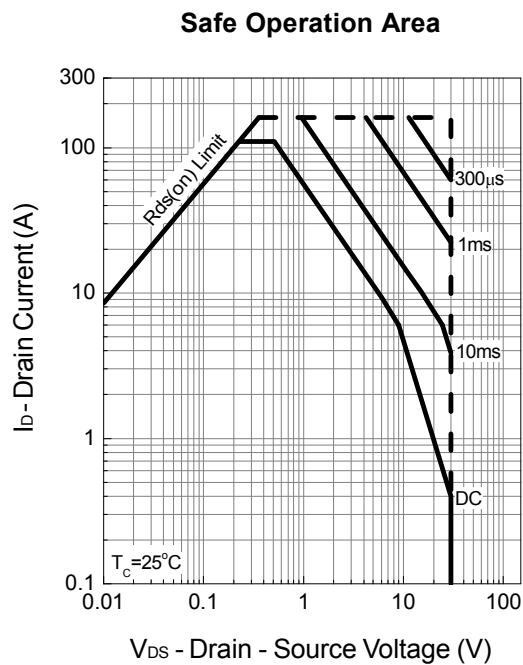
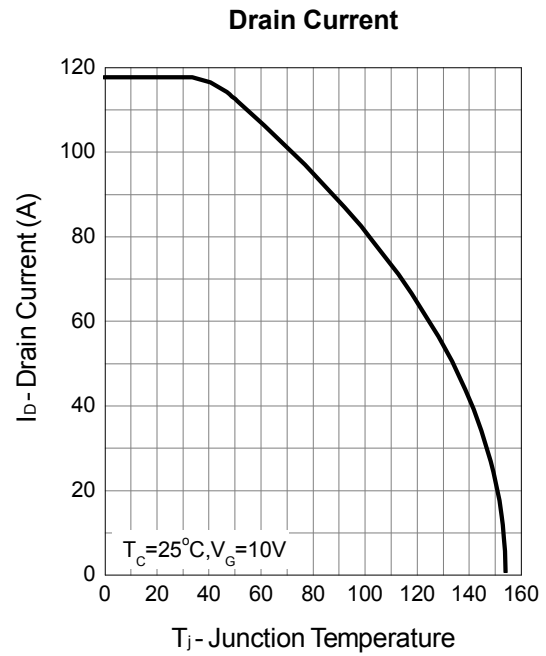
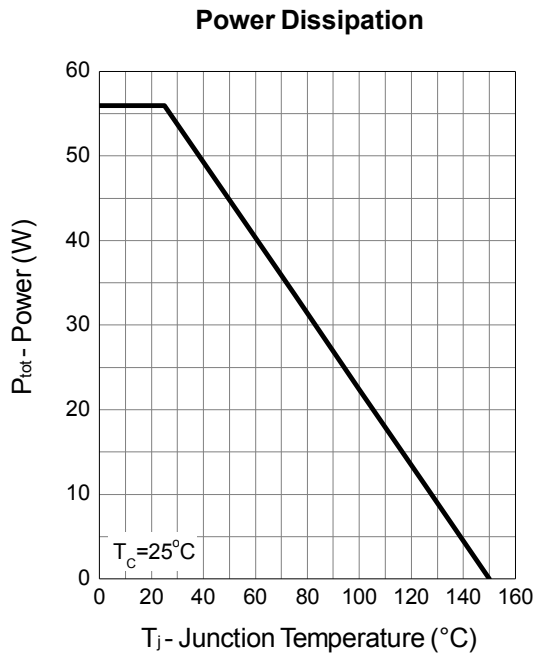



Typical Operating Characteristics (Cont.)

Safe Operation Area

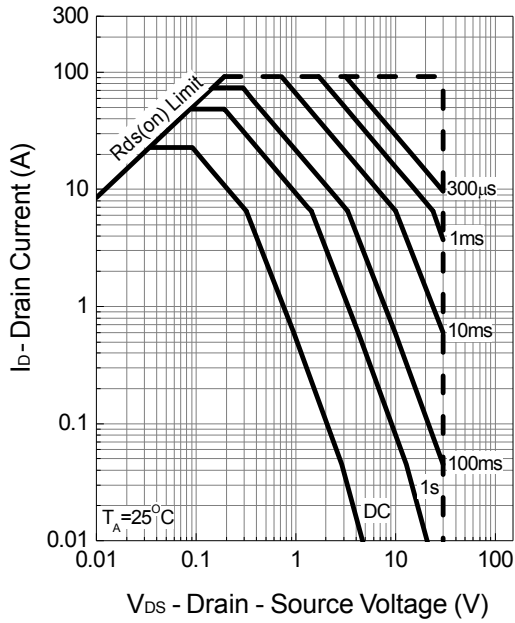

Thermal Transient Impedance

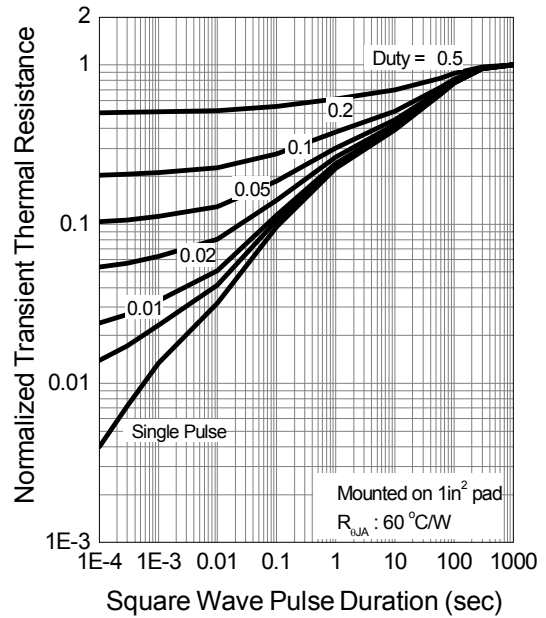

Output Characteristics

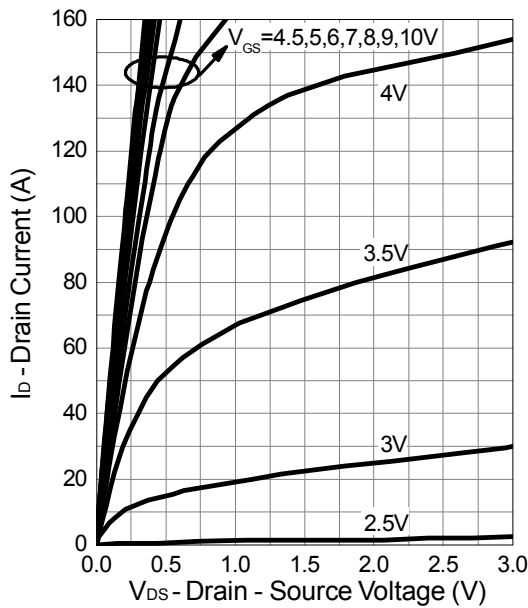

Drain-Source On Resistance

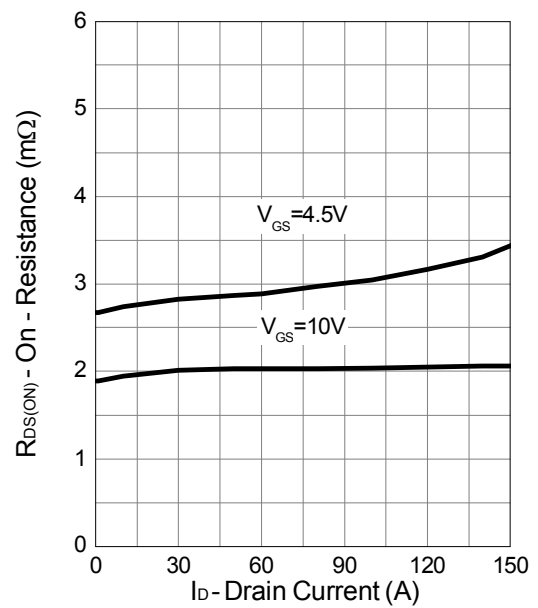



Typical Operating Characteristics (Cont.)

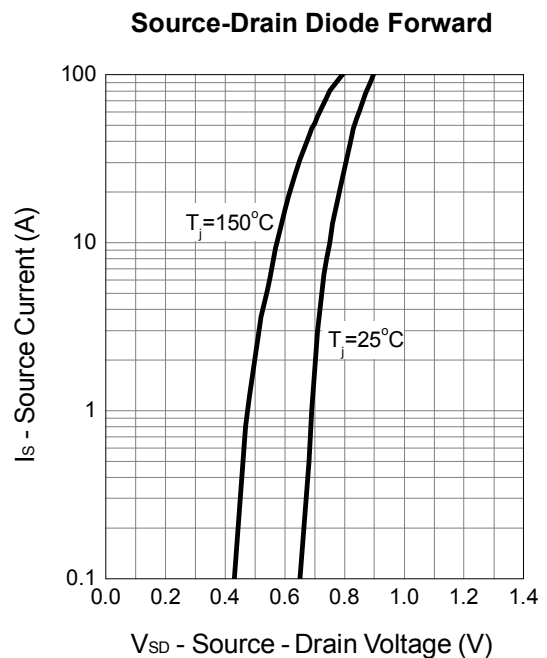
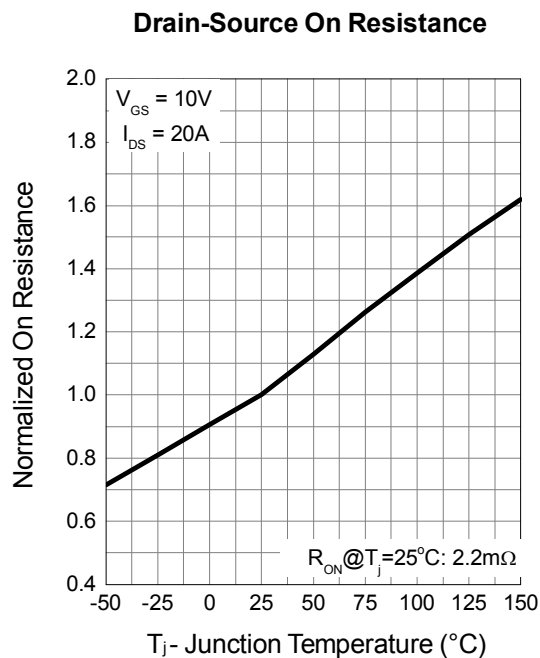
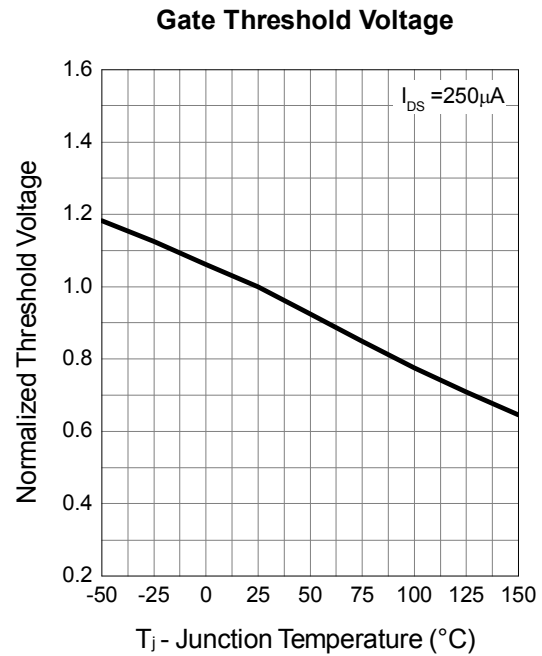
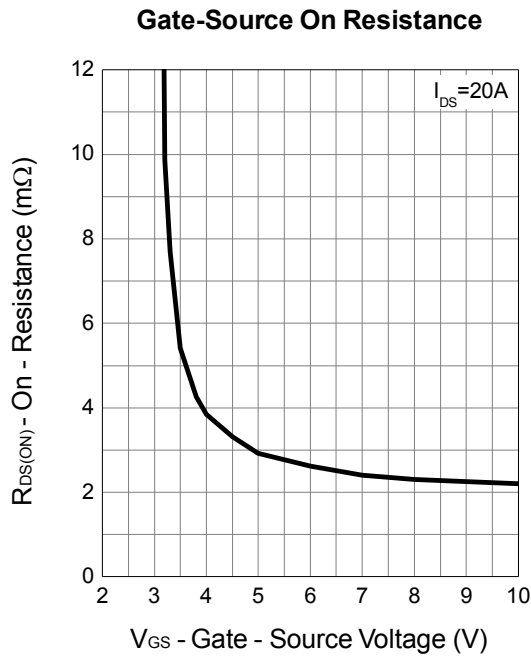



Typical Operating Characteristics (Cont.)

Capacitance

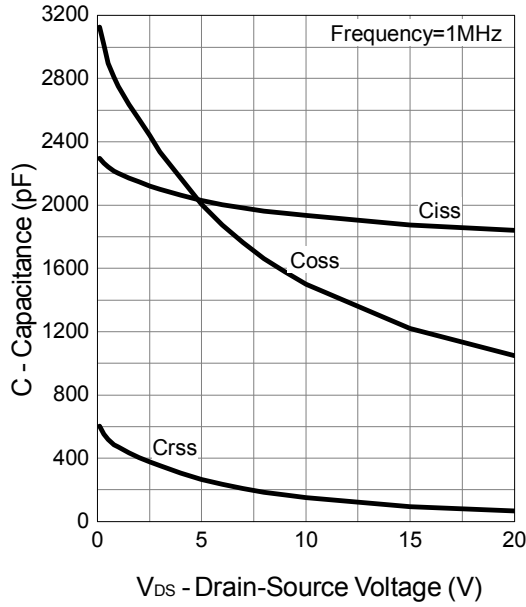

Gate Charge

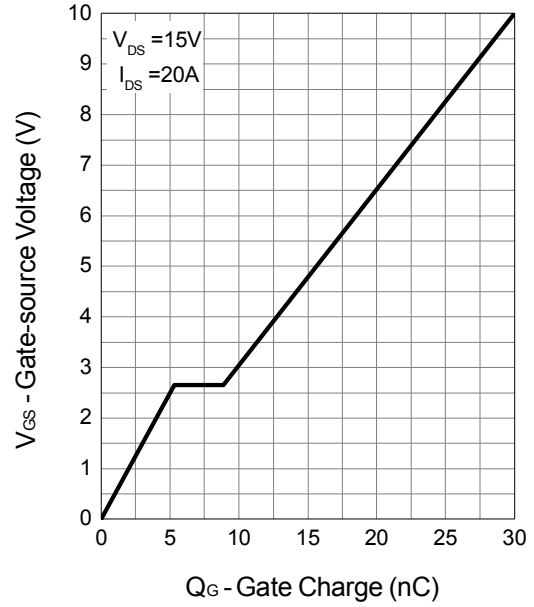

Transfer Characteristics

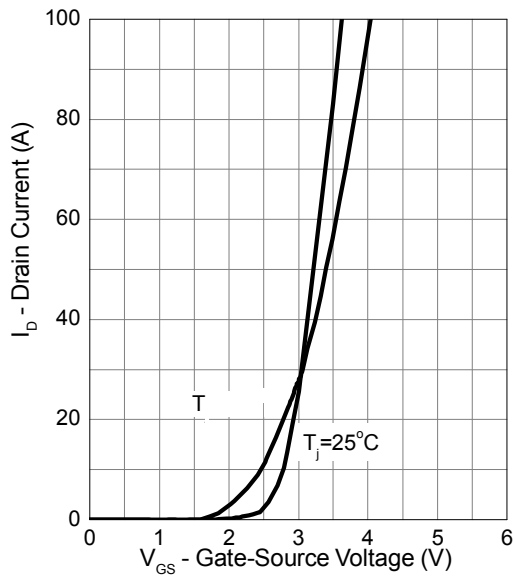

Avalanche Test Circuit and Waveforms

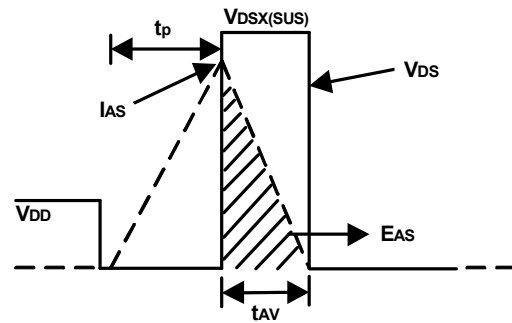
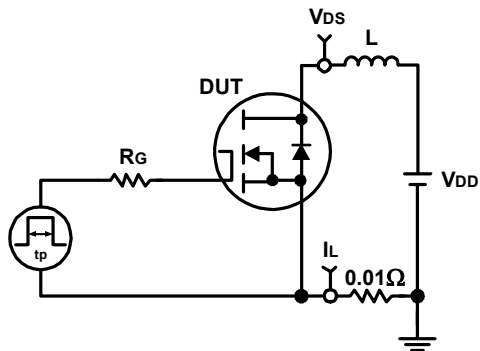

Switching Time Test Circuit and Waveforms

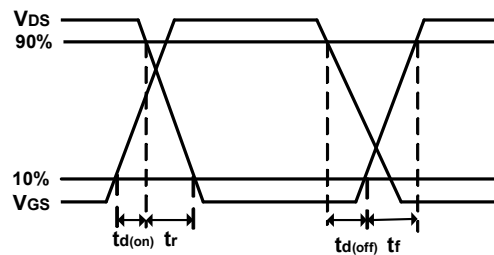
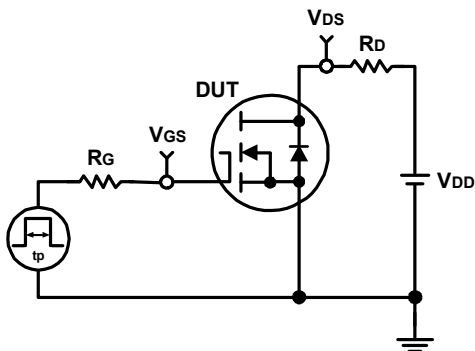



DFN5×6_8L_EP1_P OUTLINE

