

General Description

The BM114-ZUIB-DE6 is protector for lithium-ion and lithium polymer rechargeable battery with high accuracy voltage detection. It can be used for protecting single cell lithium-ion or/and lithium polymer battery packs from overcharge, overdischarge over current and short circuit. The IC has suitable protection delay functions and low power consumption property.

By using an external overcurrent detection resistor, the BM114-ZUIB-DE6 Series realizes high-accuracy overcurrent protection with less effect from temperature change.

Applications

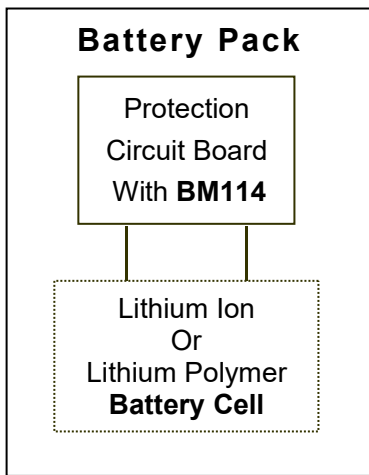

Typical Application Circuits

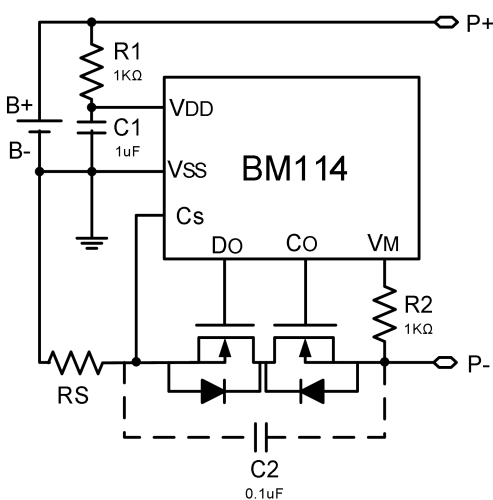

Features

- **Overcharge Detection voltage**
 - 4.525V
 - Accuracy ±20mV (25°C)
 - ±45mV (-40°C~85°C)
- **Overdischarge Detection voltage**
 - 2.350V
 - Accuracy ±50mV
- **Discharge Overcurrent Detection voltage 1**
 - 0.0105V @ $V_{DD} = 3.800V$
 - Accuracy ±1.5mV
- **Short Circuit Detection voltage**
 - Typ. 0.040V @ $V_{DD} = 3.800V$
 - Accuracy ±4mV
- **Low Supply Current**
 - Typ. 2.0uA @ $V_{DD} = 3.500V$
(Standard Working)
 - Max. 0.5uA @ $V_{DD} = 1.500V$
(With auto wake up)
- **Small Package**
 - DFN1.57*1.9-6L
- **ESD Rating**
 - HBM 2KV

Notes

R_1 and C_1 are to stabilize the supply voltage of the BM114-ZUIB-DE6. $R_1 C_1$ is hence regarded as the time constant for V_{DD} pin. R_1 and R_2 can also be a part of current limit circuit for the BM114-ZUIB-DE6. Recommended values of these elements are as follows:

- $200\Omega < R_1 \leq 1K\Omega$. A larger value of R_1 results in higher detection voltage, introducing errors.
- $1.0k\Omega \leq R_2 < 3.5K\Omega$. A larger value of R_2 possibly prevents resetting from over-discharge even with a charger.

The requirement or resistors and capacitors and the value of constants should be decided depending upon the system function and characteristics.

Marking contents

Symbol	Meaning	Top View
ZUIB	Product Name	
T6	Package Code	
YW	Lot Number	

Pin Description

Pin	Symbol	Description
1	V_M	Input pin for external negative voltage
2	C_O	FET gate connection pin for charge control, CMOS output
3	D_O	FET gate connection pin for discharge control, CMOS output
4	V_{SS}	Ground
5	V_{DD}	Power supply
6	C_S	Overcurrent detection pin

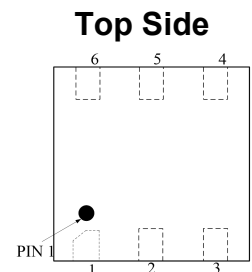

Block Diagram

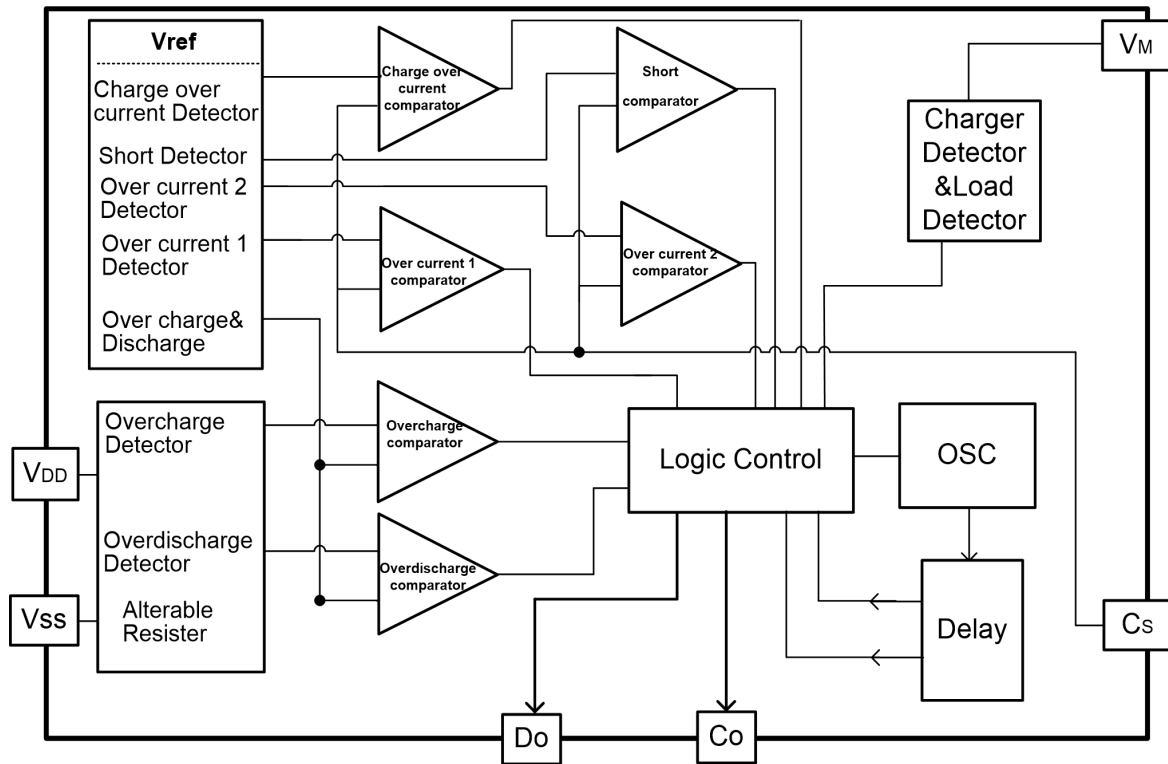

Absolute Maximum Ratings(Ta=25°C VSS=0V)

Symbol	Item	Ratings	Unit
V _{DD}	Supply Voltage	V _{SS} - 0.3 to V _{SS} + 6	V
V _{Cs}	C _s Pin Input Voltage	V _{DD} - 6 to V _{DD} + 0.3	V
V _{VM}	V _M Pin Input Voltage	V _{DD} - 28 to V _{DD} + 0.3	V
V _{Co}	Co Pin Output Voltage	V _{DD} - 28 to V _{DD} + 0.3	V
V _{Do}	Do Pin Output Voltage	V _{SS} - 0.3 to V _{DD} + 0.3	V
P _d	Power Dissipation	150	mW
T _{opt}	Operating Temperature Range	-40 to 85	°C
T _{stg}	Storage Temperature Range	-55 to 125	°C

Caution: These values must not be exceeded under any conditions.



Electrical Characteristics

(Ta=25°C unless otherwise specified)

Symbol	Item	Conditions	Min.	TYP.	Max.	Unit
DETECTION VOLTAGE AND DELAY TIME						
Vdet1	Overcharge Detection Voltage	-	4.505	4.525	4.545	V
Vrel1	Release Voltage For Overcharge Detection	-	4.325	4.375	4.425	V
Vdet2	Overdischarge Detection Voltage	-	2.300	2.350	2.400	V
Vrel2	Release Voltage For Overdischarge	-	2.475	2.550	2.625	V
Vdet3	Discharge Overcurrent Detection Voltage 1	V _{DD} = 3.800V	0.0090	0.0105	0.0120	V
Vdet4	Discharge Overcurrent Detection Voltage 2	V _{DD} = 3.800V	0.0135	0.0165	0.0195	V
Vshort	Short Protection Voltage	V _{DD} = 3.800V	0.0360	0.0400	0.0440	V
Vshort2	Short Protection Voltage 2	-	0.75 × V _{DD}	0.85 × V_{DD}	0.95 × V _{DD}	V
Vcha	Charge Overcurrent Detection Voltage	-	-0.0255	-0.0240	-0.0225	V
Vriov	Discharge Overcurrent Release Voltage	-	0.75 × V _{DD}	0.85 × V_{DD}	0.95 × V _{DD}	V
V _{OINH}	0V Battery Charge Inhibition Battery Voltage	0V battery charging unavailable	0.9	1.2	1.5	V
Tvdet1	Overcharge Detection Delay Time	-	700	1000	1300	ms
Tvdet2	Overdischarge Detection Delay Time	-	44.8	64	83.2	ms
Tvdet3	Discharge Overcurrent Detection Delay Time 1	-	2867.2	3584	4300.8	ms
Tvdet4	Discharge Overcurrent Detection Delay Time 2	-	11.2	16	20.8	ms
Tab	Charge Overcurrent Detection Delay Time	-	11.2	16	20.8	ms
Tshort	Short Detection Delay Time	-	225	375	525	us
OUTPUT RESISTANCE AND INTERNAL RESISTANCE						
R _{COH}	CO Pin Output Resistance "H"	-	2.0	4.0	8.0	kΩ
R _{COL}	CO Pin Output Resistance "L"	-	1.5	3.0	6.0	kΩ
R _{DOH}	DO Pin Output Resistance "H"	-	1.3	2.5	5.0	kΩ
R _{DOL}	DO Pin Output Resistance "L"	-	0.8	1.5	3.0	kΩ
R _{VMD}	Resistance between V _M and V _{DD}	V _{DD} =2.0V, V _M =0V	400	800	1600	kΩ
R _{VMS}	Resistance between V _M and V _{SS}	V _{DD} =3.4V, V _M =1V	9	18	36	kΩ
OPERATION VOLTAGE AND CURRENT CONSUMPTION						
V _{DD}	Operating Input Voltage	V _{DD} -V _{SS}	1.5	V_{DD}	6	V
V _M	Operating Input Voltage	V _{DD} -V _M	1.5	-	28	V
I _{DD}	Supply Current	V _{DD} = 3.5V, V _M = 0V	-	2.0	4.0	uA
I _{STANDBY}	Standby Current (with Auto wake up)	V _{DD} = 1.5V, V _M = 0V→1.5V	-	-	0.5	uA

**Electrical Characteristics** ^{1*}

(Ta = -25°C~70°C unless otherwise specified)

Symbol	Item	Conditions	Min.	TYP.	Max.	Unit
DETECTION VOLTAGE AND DELAY TIME						
Vdet1	Overcharge Detection Voltage	-	4.500	4.525	4.545	V
Vrel1	Release Voltage For Overcharge Detection	-	4.320	4.375	4.430	V
Vdet2	Overdischarge Detection Voltage	-	2.295	2.350	2.405	V
Vrel2	Release Voltage For Overdischarge	-	2.455	2.550	2.645	V
Vdet3	Discharge Overcurrent Detection Voltage 1	V _{DD} = 3.800V	0.0084	0.0105	0.0126	V
Vdet4	Discharge Overcurrent Detection Voltage 2	V _{DD} = 3.800V	0.0129	0.0165	0.0201	V
Vshort	Short Protection Voltage	V _{DD} = 3.800V	0.0350	0.0400	0.0450	V
Vshort2	Short Protection Voltage 2	-	0.75 × V _{DD}	0.85 × V_{DD}	0.95 × V _{DD}	V
Vcha	Charge Overcurrent Detection Voltage	-	-0.0265	-0.0240	-0.0215	V
Vriov	Discharge Overcurrent Release Voltage	-	0.75 × V _{DD}	0.85 × V_{DD}	0.95 × V _{DD}	V
V _{OINH}	0V Battery Charge Inhibition Battery Voltage	0V battery charging unavailable	0.8	1.2	1.6	V
Tvdet1	Overcharge Detection Delay Time	-	500	1000	1500	ms
Tvdet2	Overdischarge Detection Delay Time	-	32	64	96	ms
Tvdet3	Discharge Overcurrent Detection Delay Time 1	-	2150.4	3584	5017.6	ms
Tvdet4	Discharge Overcurrent Detection Delay Time 2	-	8	16	24	ms
Tab	Charge Overcurrent Detection Delay Time	-	8	16	24	ms
Tshort	Short Detection Delay Time	-	150	375	600	us
OUTPUT RESISTANCE AND INTERNAL RESISTANCE						
R _{COH}	CO Pin Output Resistance "H"	-	1.0	4.0	12.0	kΩ
R _{COL}	CO Pin Output Resistance "L"	-	0.8	3.0	9.0	kΩ
R _{DOH}	DO Pin Output Resistance "H"	-	0.6	2.5	7.5	kΩ
R _{DOL}	DO Pin Output Resistance "L"	-	0.4	1.5	4.5	kΩ
R _{VMD}	Resistance between V _M and V _{DD}	V _{DD} =2.0V, V _M =0V	200	800	2400	kΩ
R _{VMS}	Resistance between V _M and V _{SS}	V _{DD} =3.4V, V _M =1V	6	18	45	kΩ
OPERATION VOLTAGE AND CURRENT CONSUMPTION						
V _{DD}	Operating Input Voltage	V _{DD} -V _{SS}	1.5	V_{DD}	6	V
V _M	Operating Input Voltage	V _{DD} -V _M	1.5	-	28	V
I _{DD}	Supply Current	V _{DD} = 3.5V, V _M = 0V	-	2.0	5.0	uA
I _{STANDBY}	Standby Current (with Auto wake up)	V _{DD} = 1.5V, V _M = 0V→1.5V	-	-	1.0	uA

^{1*} The Electrical parameters for this temperature range is guaranteed by design, not tested in production.

**Electrical Characteristics** ^{1*}

(Ta = -40°C~85°C unless otherwise specified)

Symbol	Item	Conditions	Min.	TYP.	Max.	Unit
DETECTION VOLTAGE AND DELAY TIME						
Vdet1	Overcharge Detection Voltage	-	4.480	4.525	4.570	V
Vrel1	Release Voltage For Overcharge Detection	-	4.305	4.375	4.445	V
Vdet2	Overdischarge Detection Voltage	-	2.290	2.350	2.410	V
Vrel2	Release Voltage For Overdischarge	-	2.450	2.550	2.650	V
Vdet3	Discharge Overcurrent Detection Voltage 1	V _{DD} = 3.800V	0.0065	0.0105	0.0145	V
Vdet4	Discharge Overcurrent Detection Voltage 2	V _{DD} = 3.800V	0.0115	0.0165	0.0215	V
Vshort	Short Protection Voltage	V _{DD} = 3.800V	0.0340	0.0400	0.0460	V
Vshort2	Short Protection Voltage 2	-	0.75 × V _{DD}	0.85 × V _{DD}	0.95 × V _{DD}	V
Vcha	Charge Overcurrent Detection Voltage	-	-0.0285	-0.0240	-0.0195	V
Vriov	Discharge Overcurrent Release Voltage	-	0.75 × V _{DD}	0.85 × V _{DD}	0.95 × V _{DD}	V
V _{OINH}	0V Battery Charge Inhibition Battery Voltage	0V battery charging unavailable	0.7	1.2	1.7	V
Tvdet1	Overcharge Detection Delay Time	-	400	1000	1600	ms
Tvdet2	Overdischarge Detection Delay Time	-	25.6	64	102.4	ms
Tvdet3	Discharge Overcurrent Detection Delay Time 1	-	1433.6	3584	5734.4	ms
Tvdet4	Discharge Overcurrent Detection Delay Time 2	-	6.4	16	25.6	ms
Tab	Charge Overcurrent Detection Delay Time	-	6.4	16	25.6	ms
Tshort	Short Detection Delay Time	-	150	375	600	us
OUTPUT RESISTANCE AND INTERNAL RESISTANCE						
R _{COH}	CO Pin Output Resistance "H"	-	1.0	4.0	12.0	kΩ
R _{COL}	CO Pin Output Resistance "L"	-	0.8	3.0	9.0	kΩ
R _{DOH}	DO Pin Output Resistance "H"	-	0.6	2.5	7.5	kΩ
R _{DOL}	DO Pin Output Resistance "L"	-	0.4	1.5	4.5	kΩ
R _{VMD}	Resistance between V _M and V _{DD}	V _{DD} =2.0V, V _M =0V	200	800	2400	kΩ
R _{VMS}	Resistance between V _M and V _{SS}	V _{DD} =3.4V, V _M =1V	6	18	45	kΩ
OPERATION VOLTAGE AND CURRENT CONSUMPTION						
V _{DD}	Operating Input Voltage	V _{DD} -V _{SS}	1.5	V_{DD}	6	V
V _M	Operating Input Voltage	V _{DD} -V _M	1.5	-	28	V
V _{CTL}	CTL pin voltage	-	0.2	0.6	1.0	V
I _{DD}	Supply Current	V _{DD} = 3.5V, V _M = 0V	-	2.0	5.0	uA
I _{STANDBY}	Standby Current (with Auto wake up)	V _{DD} = 1.5V, V _M = 0V→1.5V	-	-	1.0	uA

^{1*} The Electrical parameters for this temperature range is guaranteed by design, not tested in production.

Function Description

Normal Condition

When VDD is between the Overdischarge Detection voltage (Vdet2) and Overcharge Detection voltage (Vdet1), and the CS pad voltage is between Charger Detection Voltage (Vcha) and the Discharge Overcurrent Detection voltage 1 (Vdet3), the outputs of DO pad and CO pad are high and the MOSFETs of charge and discharge are all on. Charging and discharging can be carried out freely.

Overcharge Condition

When VDD increases and passes Vdet1 during charging under the normal condition, the output of CO pad will change from high to low after Overcharge Detection Delay Time (Tvdet1), turning off the charging control FET.

Overcharge Protection Release Condition

The charging state can be reset and charge control FET will turn on ,as follow condition:

- (1).When the VM pin voltage is lower than 0.15 V typ., and the VDD is lower than the Overcharge Release Voltage (Vrel1), the charge control FET turns on.
- (2).When the VM pin voltage is equal to or higher than 0.15 V typ., and the VDD level is lower than the Overcharge Detection Voltage (Vdet1), the charge control FET will turn on.

Charge Overcurrent Condition

If the CS pin voltage falls below the Charge Overcurrent Detection Voltage (Vcha) during charging under normal condition and it continues for the Charge Overcurrent Delay Time (Tab) or longer, the charging control FET turns off and charging stops.

Charge Overcurrent detection works when the DO pin voltage is "H" and the CS pin voltage falls below the Charge Overcurrent Detection Voltage (Vcha). To an overdischarged battery, only when charging makes the battery voltage higher than the Overdischarge Detection voltage (Vdet2), the Charge Overcurrent Detection can act. Charge overcurrent state is released, once the VM pin voltage becomes higher than 0.15 V typ..

Overdischarge Condition

While discharging, after VDD lowers below Overdischarge Detection voltage (Vdet2), DO pad goes low after Overdischarge Detection Delay Time (Tvdet2). The DO pad would switch off the discharging control FET and stop discharging.

Overdischarge Protection Release Condition

When IC is in overdischarge condition, if a charger is connected to the battery pack, and the battery supply voltage becomes higher than Vdet2, and VM is lower than -0.3 V Typ., DO pad becomes high, allowing discharging action.

When the VM pin voltage is higher than -0.3 V Typ., the discharging state also can be reset and the output of DO becomes high when VDD becomes higher than the Overdischarge Release Voltage (Vrel2).

When a charger is connected from the battery pack, while the VDD level is lower than Vdet2, the battery pack makes charger current allowable through the internal parasitic diode.

Charger Detect Condition

When a battery in the overdischarge condition is connected to a charger and provided that the VM pin voltage is lower than -0.3 V Typ., IC releases the overdischarge condition and turns on the discharging control FET as the battery voltage

becomes higher than the Overdischarge Detection Voltage (V_{det2}) since the charger detection function works. This action is called charger detection.

Discharge Overcurrent Protection

During discharging, the current varies with load, and CS increases with the rise of the discharging current. Once CS rises up to the Discharge Overcurrent Detection voltage 1 (V_{det3}) or higher and stays longer than the Discharge Overcurrent Delay Time 1 (T_{vdet3}), DO pad switches to low, turning off the discharging control FET. If CS rises up to the Discharge Overcurrent Detection voltage 2 (V_{det4}) or higher and stays longer than the Discharge Overcurrent Delay Time 2 (T_{vdet4}), DO pad can also switch to low and turning off the discharging control FET.

After that Discharge Overcurrent state is removed, i.e. $V_M < V_{riov}$, and the circuit recovers to normal condition.

Short Circuit Protection

This function has the same principle as the overcurrent protection. But, the delay time T_{short} is far shorter than T_{vdet3} , and the detection voltage V_{short} is far higher than V_{det3} . When the circuit is shorted, CS increases rapidly. Once $CS \geq V_{short}$, DO pad switches to low, turning off the discharging control FET. After the short circuit state is removed, i.e. $V_M < V_{riov}$, the circuit recovers to the normal condition. Output types of CO and DO are CMOS level.

Short Circuit Protection 2

When the circuit is shorted, V_M increases rapidly. Once $V_M \geq V_{short2}$ and stays longer than Short Detection Delay Time (T_{short}), DO pad switches to low, turning off the discharging control FET. After the short circuit state is removed, i.e. $V_M < V_{riov}$, the circuit recovers to the normal condition.

0V battery charge inhibition function

This function inhibits the recharging when a battery whose voltage is 0V due to the self-discharge is connected. When the battery voltage is the 0 V battery charge inhibition battery voltage (V_{0INH}) or lower, the charging control FET gate is fixed to the voltage of V_M to inhibit charging. When the battery voltage is higher than V_{0INH} , charging can be performed.

Timing Charts

Operation Timing Chart (1)

Overcharge/Overdischarge Detection

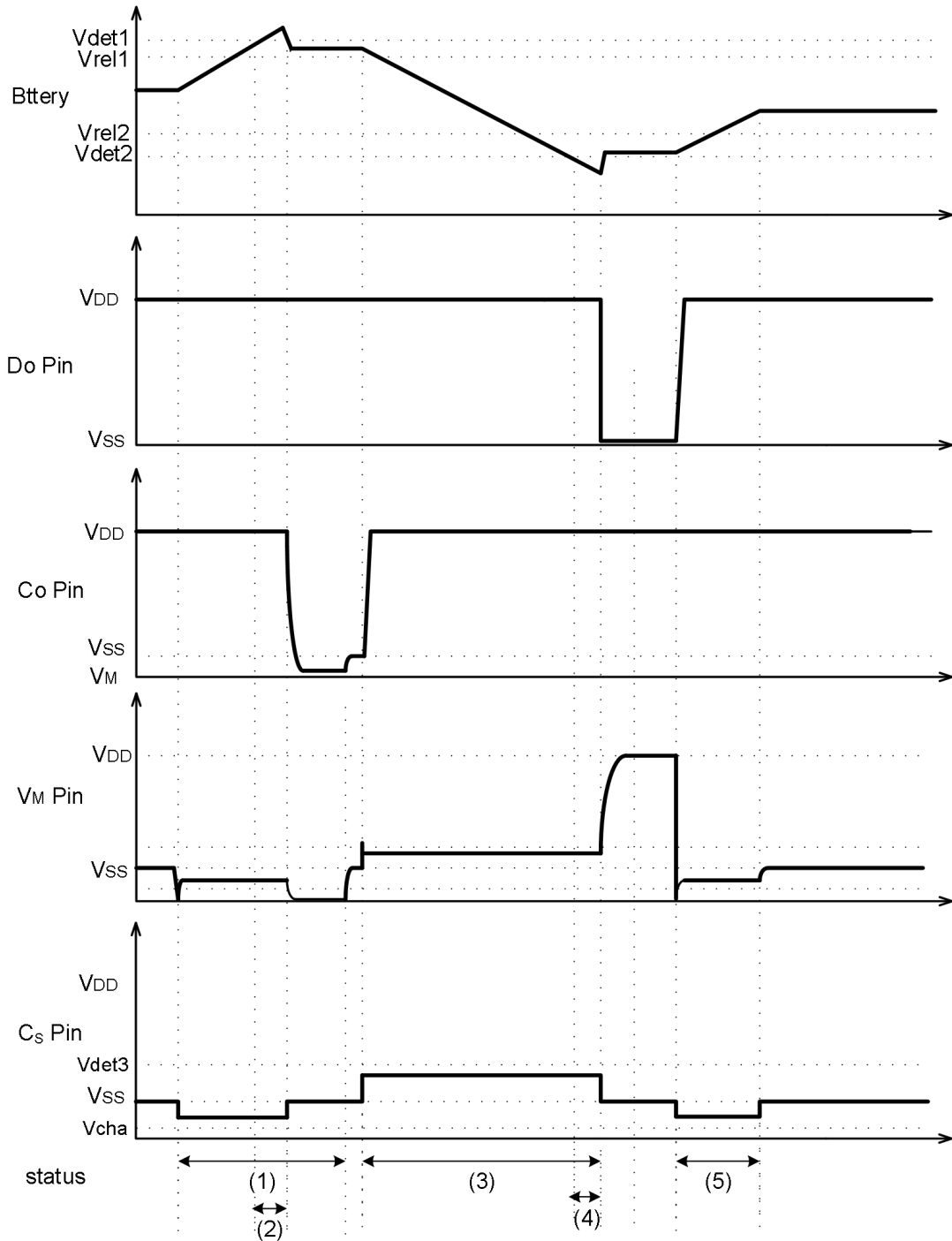

- (1) Charger connected
- (2) Overcharge Detection Delay Time
- (3) Load connected
- (4) Overdischarge Detection Delay Time
- (5) Normal charging

Operation Timing Chart (2)

Discharge Overcurrent 1, Discharge Overcurrent 2 and Short Detection

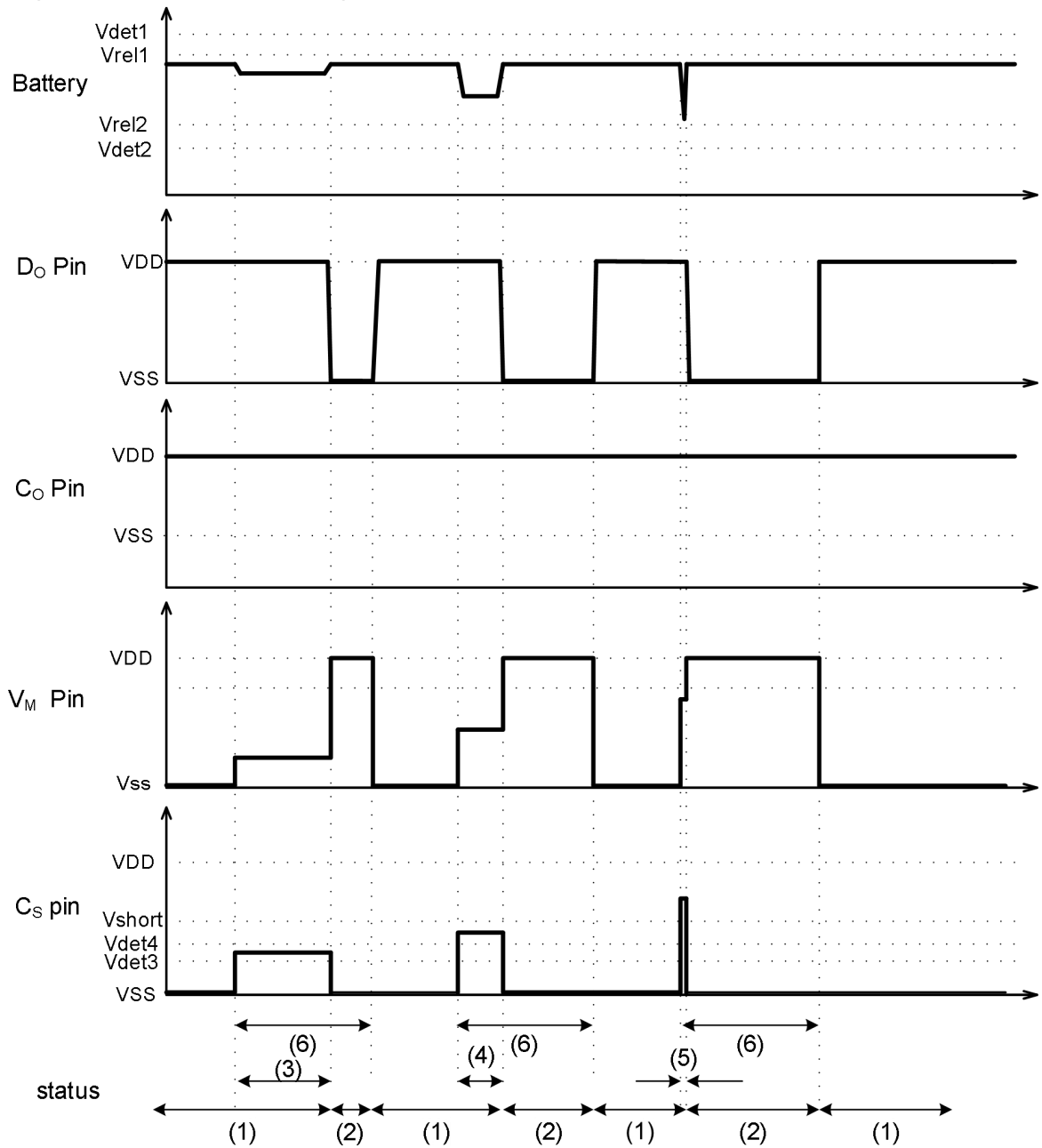

- (1) Normal status
- (2) Discharge overcurrent status
- (3) Discharge Overcurrent Detection Delay Time 1
- (4) Discharge Overcurrent Detection Delay Time 2
- (5) Short Detection Delay Time
- (6) Load connected

Operation Timing Chart (3)
Charge Overcurrent Detection

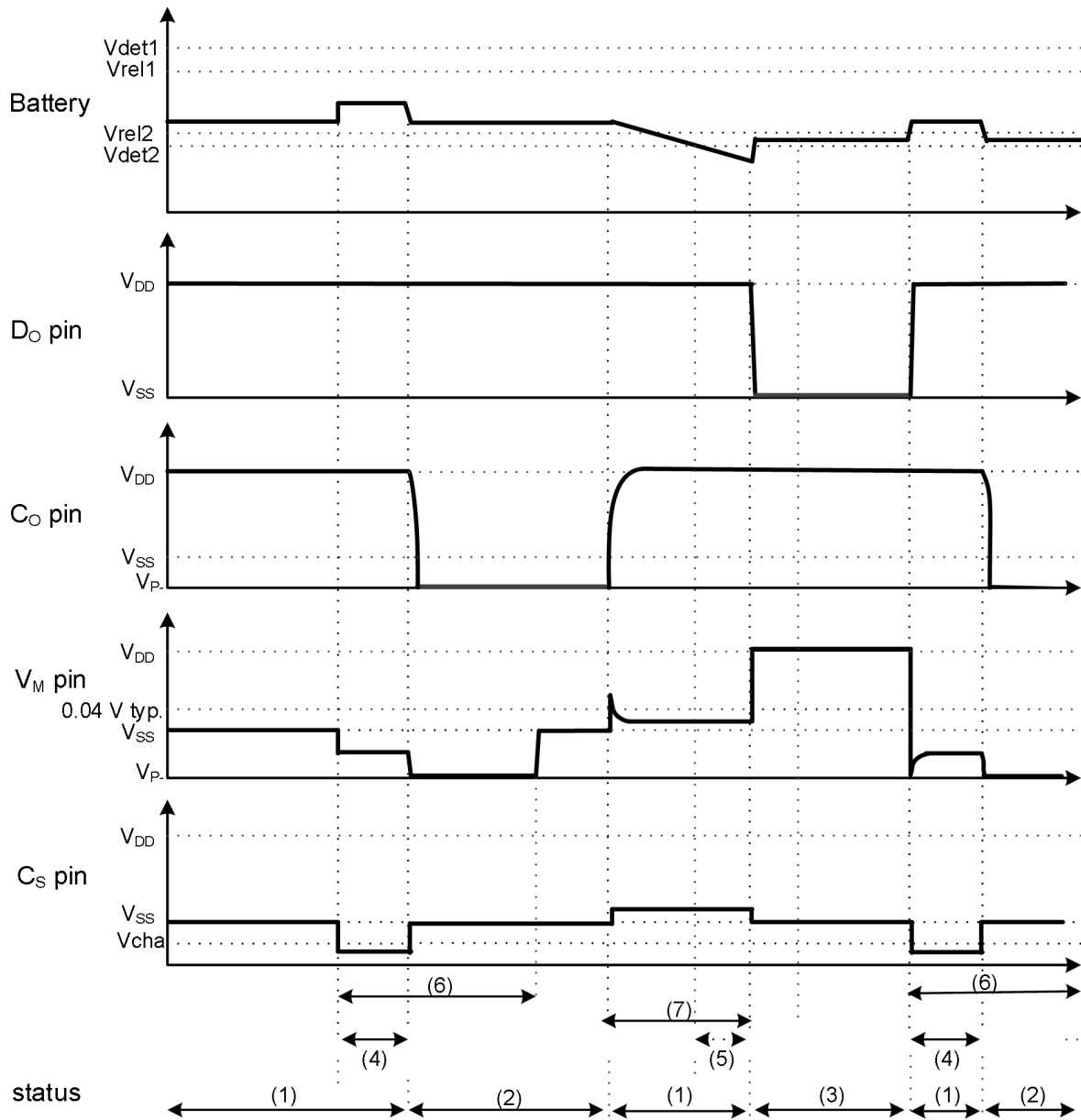

- (1) Normal status
- (2) Charge overcurrent status
- (3) Overdischarge status
- (4) Charge Overcurrent Detection Delay Time
- (5) Overdischarge Detection Delay Time
- (6) Charger connected
- (7) Load connected

Test Circuits

(1) Overcharge detection voltage and overcharge release voltage (Test circuit 1)

Set $V_1=3.5V$, the Overcharge Detection Voltage (V_{det1}) is the voltage between V_{DD} and V_{SS} to which when V_1 increases and keeps the condition for overcharge delay time, V_{CO} changes from "H" to "L". The Overcharge Release Voltage (V_{rel1}) is the voltage between V_{DD} and V_{SS} to which when V_1 decreases, V_{CO} changes from "L" to "H".

(2) Overdischarge detection voltage and over-discharge release voltage (Test circuit 1)

Set $V_1=3.5V$, the Overdischarge Detection Voltage (V_{det2}) is the voltage between V_{DD} and V_{SS} to which when V_1 decreases and keep the condition for overdischarge delay time, V_{DO} changes from "H" to "L". The overdischarge Release Voltage (V_{rel2}) is the voltage between V_{DD} and V_{SS} to which when V_1 increases, V_{DO} changes from "L" to "H".

(3) Discharge Overcurrent detection voltage and short circuit detection voltage (Test circuit 2)

Set $V_1=3.5V$, $V_2=1.0V$, $V_5=0V$ under normal condition.

The Discharge Overcurrent Detection Voltage 1 (V_{det3}) is the voltage between C_S and V_{SS} to which when C_S increases within 10 us and keep the condition for Discharge Overcurrent Delay Time 1 (T_{vdet3}), V_{DO} changes from "H" to "L".

The Discharge Overcurrent Detection Voltage 2 (V_{det4}) is the voltage between C_S and V_{SS} to which when C_S increases within 10 us and keep the condition for Discharge Overcurrent Delay Time 2 (T_{vdet4}), V_{DO} changes from "H" to "L".

The Short Circuit Detection Voltage (V_{short}) is the voltage between C_S and V_{SS} to which when C_S increases within 10us and keep the condition for Short Circuit Delay Time (T_{short}), V_{DO} changes from "H" to "L".

Set $V_1=3.5V$, $V_2=V_5=0V$ under normal condition: The Short Circuit Detection Voltage2 (V_{short2}) is the voltage between V_m and V_{SS} to which when V_m increases within 10us and keep the condition for Short Circuit Delay Time (T_{short}), V_{DO} changes from "H" to "L".

(4) Charge Overcurrent detection voltage (Test circuit 2)

Set $V_1=3.5V$, $V_2=V_5=0V$, the voltage between C_S and V_{SS} to which when V_5 decreases, V_{CO} changes from "H" to "L" is the Charge Overcurrent Detection Voltage (V_{cha}).

(5) 0V battery charge inhibiting battery voltage (Test circuit 4)

Set $V_1=1.8V$ and $V_2=-4V$, decrease V_1 gradually. The voltage between V_{DD} and V_{SS} when V_{CO} goes "L" ($V_{CO} = V_{VM}$) is the 0V battery charge inhibiting battery voltage (V_{0INH}).

(6) Normal operation current consumption and power down current consumption

(Test circuit 2)

Set $V_1=3.5V$, $V_2=V_5=0V$ under normal condition, the current I_{DD} flowing through V_{DD} pin is the normal operation consumption current (I_{DD}).

Set $V_1=3.5V$ and $V_2=V_5=0V$, let IC work in normal condition, set V_1 from 3.5V to 1.5V, then let V_M floating under overdischarge condition, the current I_{DD} flowing through V_{DD} pin is the power down current consumption ($I_{STANDBY}$).

(7) Overcharge detection delay time and overdischarge detection delay time (Test circuit 2)

Set $V_1=3.5V$, $V_2=V_5=0V$ under normal condition.

If V_1 increases to be V_{det1} or over V_{det1} and keeps the condition for some time, V_{CO} will change from "H" to "L".

The time is called overcharge detection delay time. It is used to judge whether overcharge happens indeed.

If V_1 decreases to be V_{det2} or below V_{det2} and keeps the condition for some time, V_{DO} will change from "H" to "L". The time is called overdischarge detection delay time. It is used to judge whether overdischarge happens indeed.

(8) Discharge Overcurrent detection delay time and short circuit detection delay time

(Test circuit 2)

Set $V_1=3.5V$, $V_2=1.0V$, $V_5=0V$ under normal condition.

If V_5 increases to be V_{det3} or over V_{det3} and keeps the condition for some time, V_{Do} will change from "H" to "L". The time is called discharge overcurrent delay time 1. It is used to judge whether discharge overcurrent 1 happens indeed.

If V_5 increases to be V_{det4} or over V_{det4} and keeps the condition for some time, V_{Do} will change from "H" to "L". The time is called discharge overcurrent delay time 2. It is used to judge whether discharge overcurrent 2 happens indeed.

If V_5 increases to be V_{short} or over V_{short} and keeps the condition for some time, V_{Do} will change from "H" to "L". The time is called short circuit delay time. It is used to judge whether short circuit happens indeed.

(9) Charge Overcurrent detection delay time (Test circuit 2)

Set $V_1=3.5V$, $V_2=V_5=0V$. If V_5 decreases to be V_{cha} or lower than V_{cha} and keeps the condition for some time, V_{Co} will change from "H" to "L". The time is called charge overcurrent delay time.

(10) Co pin H resistance, Co pin L resistance (Test circuit 3)

Set $V_1=3.9V$, $V_2=V_5=0V$, $I_{Co}=50\mu A$ (from Co to V_3), K_1 on and

K_2 off. $(V_1-V_3)/I_{Co}$ is the Co pin H resistance.

Set $V_1=4.6V$, $V_2=V_5=0V$, $I_{Co}=-50\mu A$ (from V_3 to Co), K_1 on and

K_2 off. V_3/I_{Co} is the Co pin L resistance.

(11) Do pin H resistance, Do pin L resistance (Test circuit 3)

Set $V_1=3.9V$, $V_2=V_5=0V$, $I_{Do}=50\mu A$ (from Do to V_4), K_1 off and

K_2 on. $(V_1-V_4)/I_{Do}$ is the Do pin H resistance.

Set $V_1=2.0V$, $V_2=V_5=0V$ and $I_{Do}=50\mu A$ (from V_4 to Do), K_1 off and K_2 on. V_4/I_{Do} is the Do pin L resistance.

(12) Internal resistance VM -VDD and VM -VSS (Test circuit 3)

Set $V_1=2.0V$, $V_2=V_5=0V$, K_1 off and K_2 off, V_1/I_{VM} is the internal resistance R_{VMD} .

Set $V_1=3.3V$, $V_2=1V$, $V_5=1V$, K_1 off and K_2 off, V_2/I_{VM} is the internal resistance R_{VMS} .

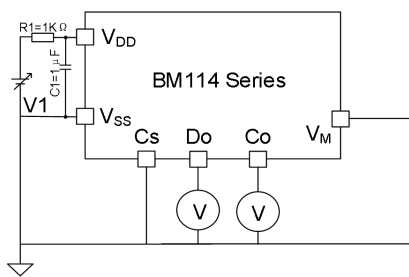

Test circuit 1

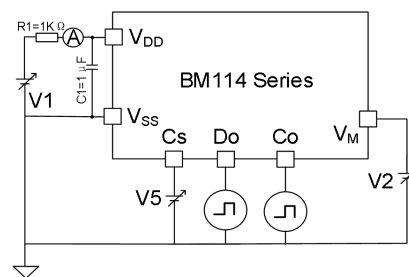

Test circuit 2

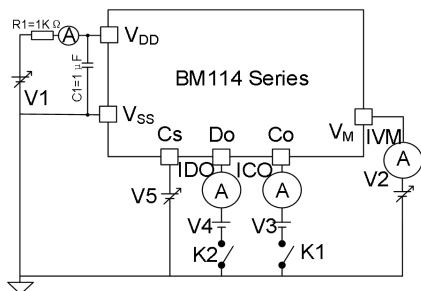

Test circuit 3

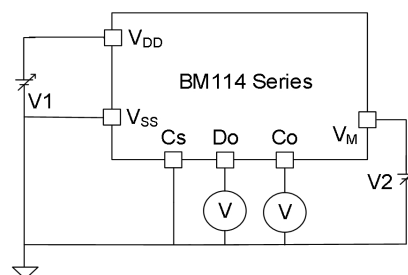

Test circuit 4

Package Outline

DFN 1.57×1.9-6L

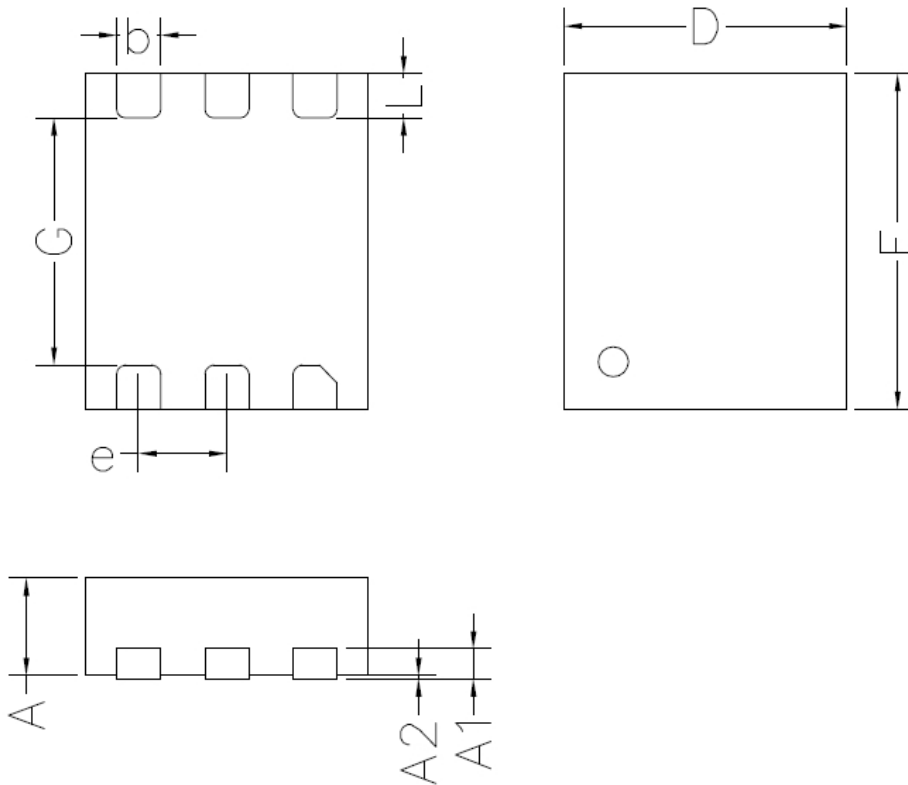

Unit: mm

Package Dimensions			
Symbols	Min	Nom	Max
D	1.52	1.57	1.62
E	1.85	1.90	1.95
L	0.25	0.30	0.35
b	0.17	0.22	0.27
e	0.45	0.50	0.55
G	1.30REF		
A	0.50	0.55	0.60
A1	0.152REF		
A2	-	-	0.03

Packing

MBB packing.7"reel: 3000pcs per reel.

PCB Layout

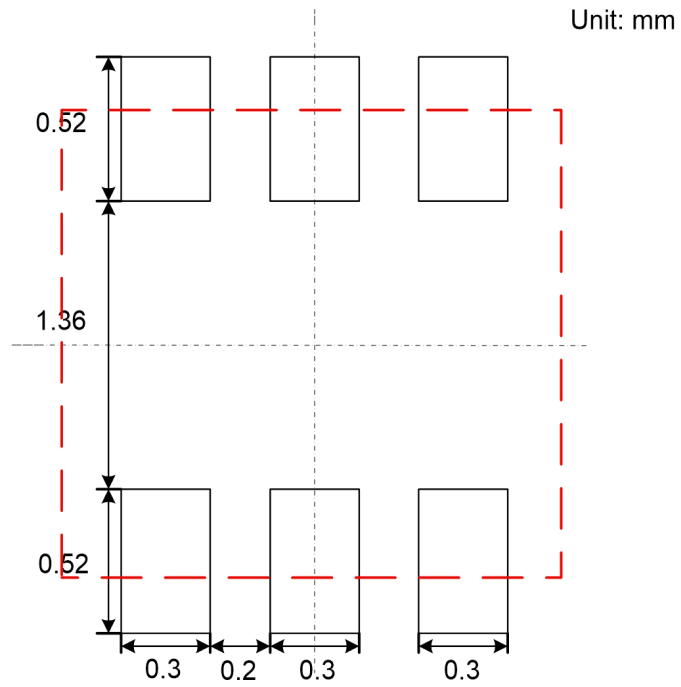

RESTRICTIONS ON PRODUCT USE

- The information contained herein is subject to change without notice.
- BYD Semiconductor Company Limited exerts the greatest possible effort to ensure high quality and reliability. Nevertheless, semiconductor devices in general can malfunction or fail due to their inherent electrical sensitivity and vulnerability to physical stress. It is the responsibility of the buyer, when utilizing products, to comply with the standards of safety in making a safe design for the entire system, including redundancy, fire-prevention measures, and malfunction prevention, to prevent any accidents, fires, or community damage that may ensue. In developing your designs, please ensure that products are used within specified operating ranges as set forth in the most recent products specifications.
- The products listed in this document are intended for usage in general electronics applications (computer, personal equipment, office equipment, measuring equipment, industrial robotics, domestic appliances, etc.). These products are neither intended nor warranted for usage in equipment that requires extraordinarily high quality and/or reliability or a malfunction or failure of which may cause loss of human life or bodily injury (“Unintended Usage”). Unintended Usage include atomic energy control instruments, airplane or spaceship instruments, transportation instruments, traffic signal instruments, combustion control instruments, medical instruments, all types of safety devices, etc.. Unintended Usage of products listed in this document shall be made at the customer’s own risk.