

One-Cell Li Battery Protectors

General Description

The BM192-MCDA-CE is protector for lithium-ion and lithium polymer rechargeable battery with high accuracy voltage detection. It can be used for protecting single cell lithium-ion or/and lithium polymer battery packs from overcharge, overdischarge, overcurrent and short circuit. The IC has suitable protection delay functions and low power consumption property.

Applications

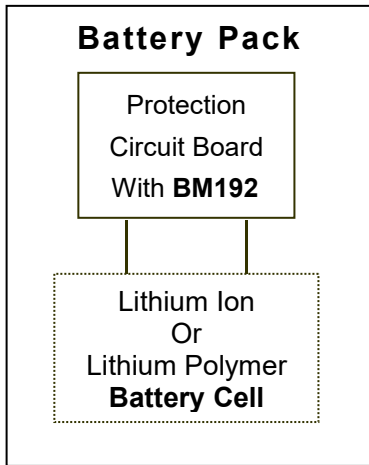

Features

- **Overcharge Detection Voltage**
 - 4.300V
 - Accuracy $\pm 35\text{mV}$ ($T_a=25^\circ\text{C}$)
 - $\pm 75\text{mV}$ ($T_a=-40^\circ\text{C}\sim 85^\circ\text{C}$)
- **Overdischarge Detection Voltage**
 - 2.500V
 - Accuracy $\pm 100\text{mV}$ ($T_a=25^\circ\text{C}$)
- **Discharge Overcurrent Detection Voltage**
 - 0.120V ($V_{DD} = 3.300\text{V}$)
 - Accuracy $\pm 20\text{mV}$ ($T_a=25^\circ\text{C}$)
- **Short Circuit Detection Voltage**
 - Typ. 0.800V ($V_{DD} = 3.300\text{V}$)
 - Accuracy $\pm 150\text{mV}$ ($T_a=25^\circ\text{C}$)
- **Low Current Consumption**
 - Typ. 4.0uA ($V_{DD} = 3.900\text{V}$, $T_a=25^\circ\text{C}$) (Standard working current)
 - Typ. 0.1uA ($V_{DD} = 2.000\text{V}$, $T_a=25^\circ\text{C}$) (Without auto wake up)
- **0V charge function is allowed**
- **Small Package**
 - DFNWB2.2*2.9-6L
- **FET general characteristics**
 - $V_{DS}=20\text{V}$
 - $R_{SS(ON)}=34\text{ m}\Omega$ ($V_{GS}=3.7\text{V}$, $I_D=1\text{A}$)
 - ESD Rating: 2000V HBM

Typical Application Circuits

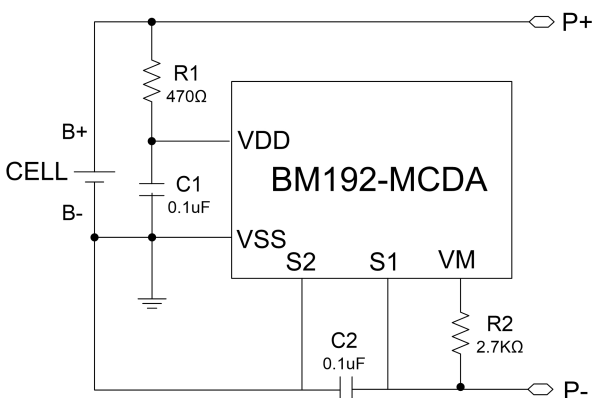

Notes

R_1 and C_1 are to stabilize the supply voltage of the BM192-MCDA-CE. R_1 C_1 is hence regarded as the time constant for V_{DD} pin. R_1 and R_2 can also be a part of current limit circuit for the BM192-MCDA-CE. Recommended values of these elements are as follows:

- $R_1 < 1\text{K}\Omega$. A larger value of R_1 results in higher detection voltage, introducing errors.
- $1.5\text{k}\Omega < R_2 < 4\text{K}\Omega$. A larger value of R_2 possibly prevents resetting from overdischarge even with a charger.
- $R_1 + R_2 > 1.6\text{K}\Omega$. Smaller values may lead to power consumption over the maximum dissipation rating of the BM192-MCDA-CE.

The requirement or resistors and capacitors and the value of constants should be decided depending upon the system function and character

Marking contents

Symbol	Meaning	Top View
MCDA	Product Name	
CE	Package Code	
YW	Lot Number	

Block Diagram

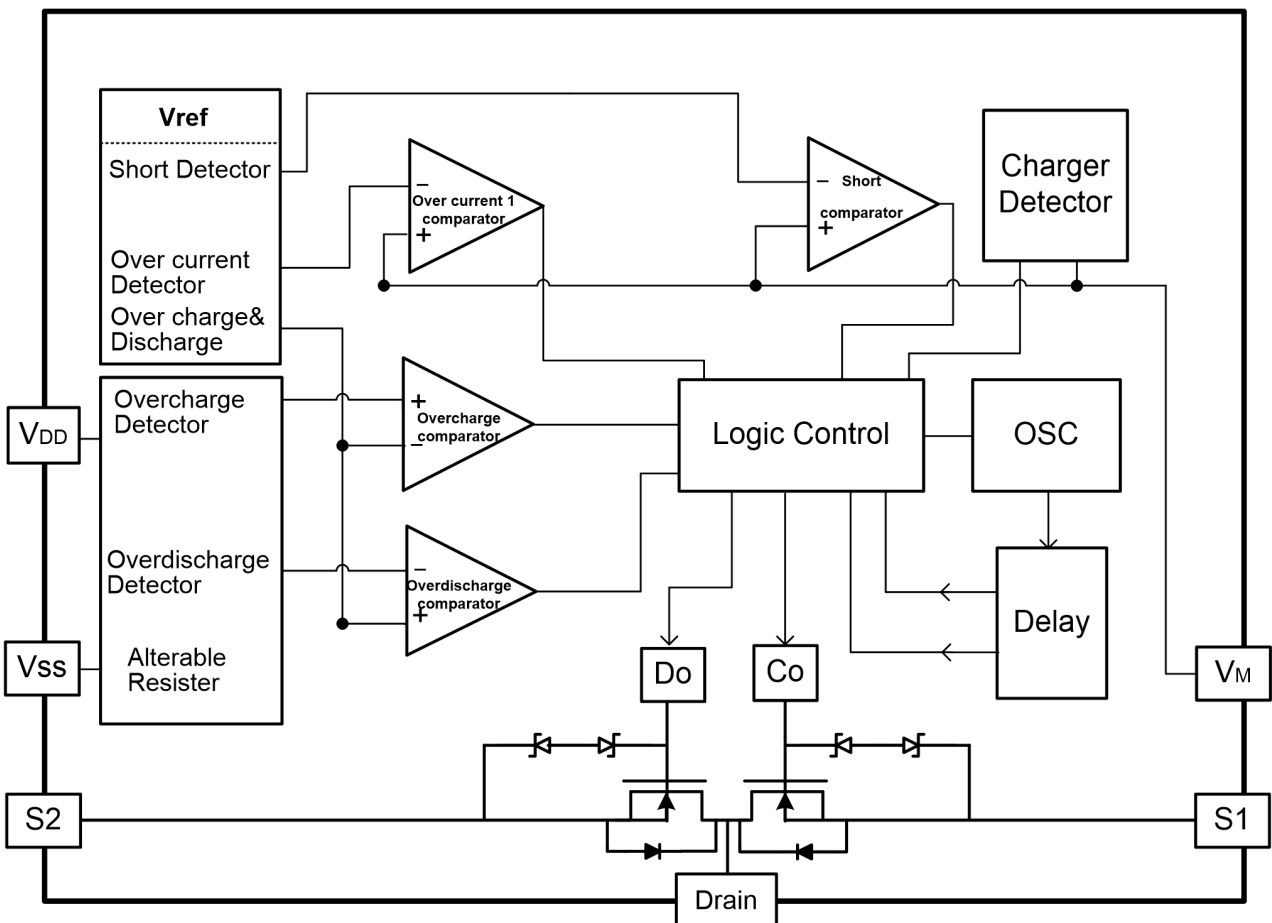

Pin Description

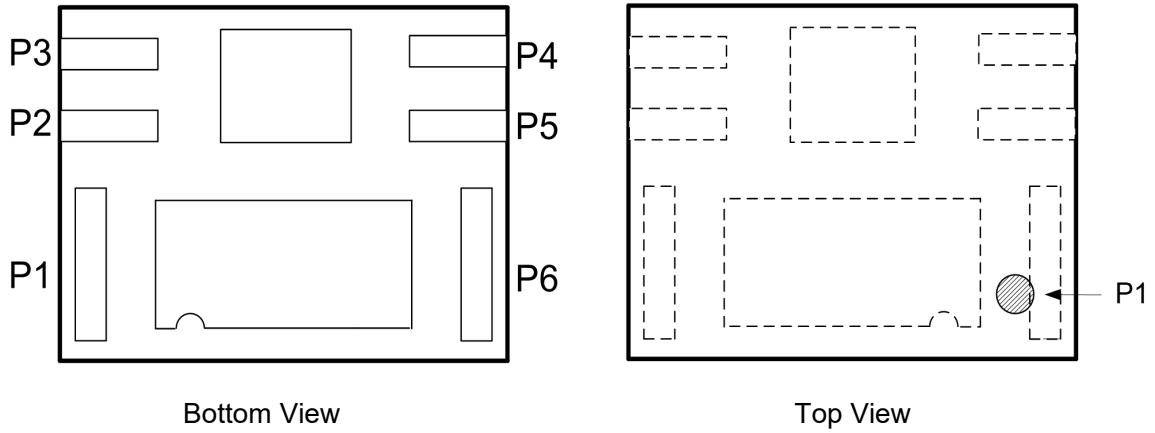

Pin	Symbol	Description
P1	S2	The source terminal of MOSFET switch for Overdischarge control
P2	VSS	Ground
P3	VDD	Power supply
P4	NC	No Connection
P5	VM	Connected to charger's negative pin
P6	S1	The source terminal of MOSFET switch for Overcharge control
P7	IS	The substrate of IC, IS should be floating
P8	MS	The common drain terminal of MOS, MS should be floating

**Electrical Characteristics** ^{1*}

(Ta=25°C unless otherwise specified)

Symbol	Item	Conditions	Min.	Typ.	Max.	Unit
DETECTION VOLTAGE AND DELAY TIME						
Vdet1	Overcharge Detection Voltage		4.265	4.300	4.335	V
Vrel1	Release Voltage For Overcharge Detection		4.050	4.100	4.150	V
Vdet2	Overdischarge Detection Voltage		2.400	2.500	2.600	V
Vrel2	Release Voltage For Overdischarge		2.500	2.600	2.700	V
Vdet3	Discharge Overcurrent Detection Voltage	V _{DD} = 3.300V	0.100	0.120	0.140	V
Vshort	Short Protection Voltage	V _{DD} = 3.300V	0.650	0.800	0.950	V
Vcha	Charger Detection (Charge Overcurrent)		-0.150	-0.120	-0.090	V
V0cha	0V Battery Charge Starting Charger Voltage	Applied for 0V battery charge function	1.2	-	-	V
Tvdet1	Overcharge detection Delay Time	V _{DD} = 4.0V→4.4V	2300	4600	6900	ms
Tvrel1	Overcharge Release Delay Time	V _{DD} = 4.4V→4.0V	10	25	40	ms
Treset	Overcharge Reset Delay Time	V _{DD} = 4.4V→4.0V→4.4V	8	23	38	ms
Tvdet2	Overdischarge Detection Delay Time	V _{DD} = 4.0V→2.0V	18	36	54	ms
Tvrel2	Overdischarge Release Delay Time	V _{DD} = 2.0V→3.0V, V _M = 0V	1.1	2.2	3.3	ms
Tvdet3	Discharge Overcurrent Detection Delay Time	V _{DD} = 3.3V, V _M = 0V→0.2V	13.5	27	40.5	ms
Tab	Charge Overcurrent Detection Delay Time	V _{DD} = 3.3V, V _M = 0V→-0.2V	9	18	27	ms
Tshort	Short Detection Delay Time	V _{DD} = 3.3V, V _M = 0V→1.2V	210	420	630	us
Tvrel3	Discharge Overcurrent Release Delay Time	V _{DD} = 3.3V, V _M = 0.2V→0 V	1.1	2.2	3.3	ms
OUTPUT VOLTAGE AND V_M INTERNAL RESISTANCE						
R _{VMD}	Resistance between V _M and V _{DD}	V _{DD} =2.0V, V _M =0V	100	600	900	kΩ
R _{VMS}	Resistance between V _M and V _{SS}	V _{DD} =3.3V, V _M =1V	60	100	300	kΩ
OPERATION VOLTAGE AND CURRENT CONSUMPTION						
V _{DD}	Operating Input Voltage	V _{DD} -V _{SS}	1.6	V_{DD}	8	V
V _M	Operating Input Voltage	V _{DD} -V _M	1.5	-	28	V
I _{DD}	Supply Current	V _{DD} = 3.9V, V _M = 0V	-	4.0	6.0	uA
I _{STANDBY}	Standby Current	V _{DD} = 2.0V, V _M = 0V→2.0V	-	0.1	0.7	uA

^{1*} The Electrical parameters for this temperature range is guaranteed by design, not tested in production.

Electrical Characteristics ^{1*}

(Ta=-40°C~85°C unless otherwise specified)

Symbol	Item	Conditions	Min.	Typ.	Max.	Unit
DETECTION VOLTAGE AND DELAY TIME						
Vdet1	Overcharge Detection Voltage		4.250	4.300	4.350	V
Vrel1	Release Voltage For Overcharge Detection		4.030	4.100	4.170	V
Vdet2	Overdischarge Detection Voltage		2.400	2.500	2.600	V
Vrel2	Release Voltage For Overdischarge		2.500	2.600	2.700	V
Vdet3	Discharge Overcurrent Detection Voltage	V _{DD} = 3.300V	0.090	0.120	0.150	V
Vshort	Short Protection Voltage	V _{DD} = 3.300V	0.500	0.800	1.100	V
Vcha	Charger Detection (Charge Overcurrent)		-0.160	-0.120	-0.080	V
V0cha	0V Battery Charge Starting Charger Voltage	Applied for 0V battery charge function	1.2	-	-	V
Tvdet1	Overcharge detection Delay Time	V _{DD} = 4.0V→4.4V	1840	4600	7360	ms
Tvrel1	Overcharge Release Delay Time	V _{DD} = 4.4V→4.0V	8	25	41	ms
Treset	Overcharge Reset Delay Time	V _{DD} = 4.4V→4.0V→4.4V	6	23	39	ms
Tvdet2	Overdischarge Detection Delay Time	V _{DD} = 4.0V→2.0V	14.4	36	57.6	ms
Tvrel2	Overdischarge Release Delay Time	V _{DD} = 2.0V→3.0V, V _M = 0V	0.88	2.2	3.52	ms
Tvdet3	Discharge Overcurrent Detection Delay Time	V _{DD} = 3.3V, V _M = 0V→0.2V	10.8	27	43.2	ms
Tab	Charge Overcurrent Detection Delay Time	V _{DD} = 3.3V, V _M = 0V→-0.2V	7.2	18	28.8	ms
Tshort	Short Detection Delay Time	V _{DD} = 3.3V, V _M = 0V→1.2V	168	420	672	us
Tvrel3	Discharge Overcurrent Release Delay Time	V _{DD} = 3.3V, V _M = 0.2V→0 V	0.88	2.2	3.52	ms
OUTPUT VOLTAGE AND V_M INTERNAL RESISTANCE						
R _{VMD}	Resistance between V _M and V _{DD}	V _{DD} =2.0V, V _M =0V	75	600	1300	kΩ
R _{VMS}	Resistance between V _M and V _{SS}	V _{DD} =3.3V, V _M =1V	40	100	400	kΩ
OPERATION VOLTAGE AND CURRENT CONSUMPTION						
V _{DD}	Operating Input Voltage	V _{DD} -V _{SS}	1.6	V_{DD}	8	V
V _M	Operating Input Voltage	V _{DD} -V _M	1.5	-	28	V
I _{DD}	Supply Current	V _{DD} = 3.9V, V _M = 0V	-	4.0	7.0	uA
I _{STANDBY}	Standby Current	V _{DD} = 2.0V, V _M = 0V→2.0V	-	0.1	1.0	uA

^{1*} The Electrical parameters for this temperature range is guaranteed by design, not tested in production.

**Electrical Characteristics**^{1*} (Ta=25°C, GND=0V unless otherwise specified)

Parameter	Symbol	Min.	Typ.	Max.	Unit	Notes
Drain current at cut off of MOS-FET	I _{DSS}			1	uA	V _{ds} =20V
Source -source on state resistance 1	R _{SS(on)1}	33	43	60	mΩ	V _{dd} =2.6V , I _D =1.0A
Source -source on state resistance 2	R _{SS(on)2}	24	34	48	mΩ	V _{dd} =3.7V , I _D =1.0A
Source -source on state resistance 3	R _{SS(on)3}	23	33	45	mΩ	V _{dd} =4.2V , I _D =1.0A
Body Diode-Forward Voltage	V _{SD}	0.4	0.74	1.2	V	I _s =1.0A , V _{GS} =0V

^{1*} The Electrical parameters for this temperature range is guaranteed by design, not tested in production.

Electrical Characteristics^{1*} (Ta=25°C, GND=0V unless otherwise specified)

Item	Symbol	Test condition	Min.	Typ.	Max.	Unit	Note
Discharge Overcurrent Detect Current	I _{det3 1}	VDD=2.6V	1.8	2.8	4.2	A	V _{det3} =0.120V V _{cha} =-0.120V
	I _{det3 2}	VDD=3.7V	2.3	3.5	5.3	A	
	I _{det3 3}	VDD=4.2V	2.3	3.6	5.5	A	
Charge Overcurrent Detect Current	I _{cha 1}	VDD=2.6V	1.6	2.8	4.5	A	
	I _{cha 2}	VDD=3.7V	2.0	3.5	5.6	A	
	I _{cha 3}	VDD=4.2V	2.0	3.6	5.8	A	

^{1*} The Electrical parameters for this temperature range is guaranteed by design, not tested in production.

Absolute Maximum Ratings (Ta=25°C, V_{SS}=0V)

Item	Symbol	Ratings	Unit
Supply Voltage	V _{DD}	-0.3 to 8	V
V _M Pin Input Voltage	V _M	V _{DD} -28 to V _{DD} +0.3	V
Gate-Source Voltage	V _{GS}	±12	V
Drain- Source Voltage	V _{DS}	20	V
Drain Current	I _D	8	A
Power Consumption	P _d	150	mW
Operating Temperature Range	T _a	-40 to 85	°C
Storage Temperature Range	T _{stg}	-55 to 125	°C

Caution: These values must not be exceeded under any conditions!

Function Description

Normal Condition:

V_{DD} is between the Overdischarge Detection Voltage (V_{det2}) and Overcharge Detection Voltage (V_{det1}) and the V_M voltage is between Charger Detection Voltage (V_{cha}) and the Discharge Overcurrent Detection Voltage (V_{det3}), therefore the MOS-FET of charge and discharge are all on. Charging and discharging can be carried out freely.

Overcharge Condition:

When V_{DD} increases and passes V_{det1} during charging under the normal condition, the charge control FET turns off after Overcharge Detection Delay Time (T_{vdet1}). If, within T_{vdet1} , V_{DD} becomes lower than V_{det1} and stays for duration shorter than Overcharge Reset Delay Time (T_{reset}) before rising up over V_{det1} again, this type of instantaneous falling of V_{DD} is ignored. Otherwise, if the time V_{DD} stays lower than V_{det1} is longer than T_{reset} , the timing related to T_{vdet1} shall be reset.

Charge Overcurrent Condition:

If the V_M voltage falls below the Charger Detection Voltage (V_{cha}) during charging under normal condition and it continues for the Charge Overcurrent Delay Time (T_{vcha}) or longer, the charge control FET turns off and charging stops. This action is called the charge overcurrent detection.

Charge overcurrent detection works when the discharging control FET is on and the V_M voltage falls below the Charger Detection Voltage (V_{cha}). To an overdischarged battery, only when charging makes the battery voltage higher than the Overdischarge Detection Voltage (V_{det2}), the charge overcurrent detection can act. Charge overcurrent state is released, once the voltage difference between V_M and V_{SS} becomes less than the Charge Overcurrent Detection Voltage (V_{cha}).

Overcharge Protection Release Condition:

The charging state can be reset and charge control FET will turn on ,as follow condition:

- (1) When the V_M voltage is between V_{det3} and V_{cha} , V_{DD} becomes lower than the Overcharge Release Voltage (V_{rel1}) , and stays longer than Overcharge Release Delay Time (T_{vrel1}), the charge control FET turns on.
- (2) When a charger is disconnected with the battery pack, and the V_{DD} level is lower than V_{det1} , the charge control FET turns on.

Note: when a charger keep connecting, even if V_{DD} level is lower than V_{rel1} , the overcharge state will not release and charge control FET keep off until disconnect the charger with the battery pack.

Overdischarge Condition:

While discharging, after V_{DD} lowers below Overdischarge Detection Voltage (V_{det2}), the discharge control FET turns off after Overdischarge Detection Delay Time (T_{vdet2}), discharging is stopped.

Overdischarge Protection Release Condition:

When IC is in overdischarge condition, if a charger is connected to the battery pack, and the battery supply voltage becomes higher than V_{det2} , the discharge control FET turns on, allowing discharging action.

The discharging state also can be reset and the output of Do becomes high when V_{DD} becomes higher than the Overdischarge Release Voltage (V_{rel2}), V_M is between V_{det3} and V_{cha} , and stays longer than Release Delay Time (T_{vrel2}).

When a charger is connected from the battery pack, while the V_{DD} level is lower than V_{det2} , the battery pack makes charger current allowable through the internal parasitic diode.

Charger Detect Condition:

When a battery in the overdischarge condition is connected to a charger and provided that the V_M voltage is lower than the Charger Detection Voltage (V_{cha}), IC releases the overdischarge condition and turns on the discharge control FET as the battery voltage becomes higher than the Overdischarge Detection Voltage (V_{det2}) since the charger detection function works. This action is called charger detection.

When a battery in the overdischarge condition is connected to a charger and provided that the V_M pin voltage is between the Charger Detection Voltage (V_{cha}) and Discharge Overcurrent Detection Voltage (V_{det3}), IC releases the overdischarge condition when the battery voltage reaches the Overdischarge Release Voltage (V_{rel2}) or higher.

Discharge Overcurrent Protection:

During discharging, the current varies with load, and V_M increases with the rise of the discharging current. Once V_M rises up to the Discharge Overcurrent Detection Voltage (V_{det3}) or higher and stays longer than the Discharge Overcurrent Delay Time (T_{vdet3}), IC will turn off the discharge control FET. After that Discharge Overcurrent state is removed, i.e. $V_M < V_{det3}$, and the circuit recovers to normal condition. The current of Discharge Overcurrent protection is related to V_{det3} and the ON resistance of the two FETs ($R_{SS(on)}$).

Short Circuit Protection:

This function has the same principle as the overcurrent protection. But, the Short Circuit Protection Delay Time (T_{short}) is far shorter than T_{vdet3} and T_{vdet4} , and the Short Protection Detection Voltage (V_{short}) is far higher than V_{det3} and V_{det4} . When the circuit is shorted, V_M increases rapidly. Once $V_M \geq V_{short}$, IC will turn off the discharge control FET. After the short circuit state is removed, i.e. $V_M < V_{det3}$, the circuit recovers to the normal condition. The short circuit peak current is related to V_{short} and the ON resistance of the two FETs ($R_{SS(on)}$).

0V battery charge function:

This function is used to recharge the connected battery whose voltage is 0V due to the self-discharge. When the 0 V battery charge starting charger voltage (V_{0cha}) or higher is applied between P+ and P- pins (in the Typical Application Circuits of Page1) by connecting a charger, the charge control FET gate is fixed to V_{DD} pin voltage. When the voltage between the gate and source of the charge control FET becomes equal to or higher than the turn-on voltage by the charger voltage, the charge control FET turns on to start charging. At this time, the discharge control FET is off and the charging current flows through the internal parasitic diode in the discharge control FET. When the battery voltage becomes equal to or higher than the Overdischarge Detection Voltage (V_{det2}), the IC enters the normal condition

BM192-MCDA-CE

Operation Timing Chart (1) Overcharge, Timer Reset for Overcharge

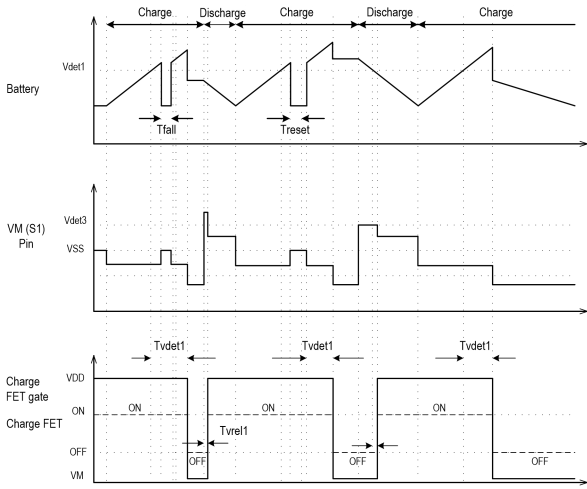

Operation Timing Chart (2) Overcharge/Overdischarge Detection

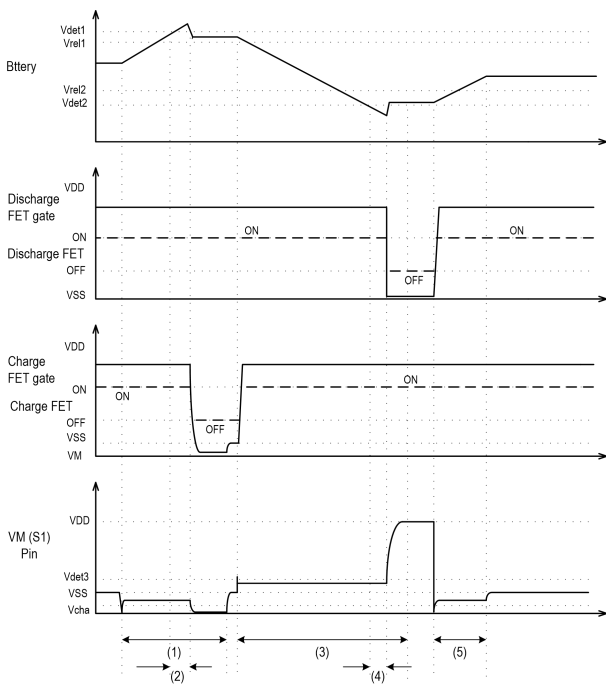

- (1) Charger connected
- (2) Overcharge Detection Delay Time (Tvdet1)
- (3) Load connected
- (4) Overdischarge Detection Delay Time (Tvdet2)
- (5) Normal charging

Operation Timing Chart (3) Discharge Overcurrent and Short Protection

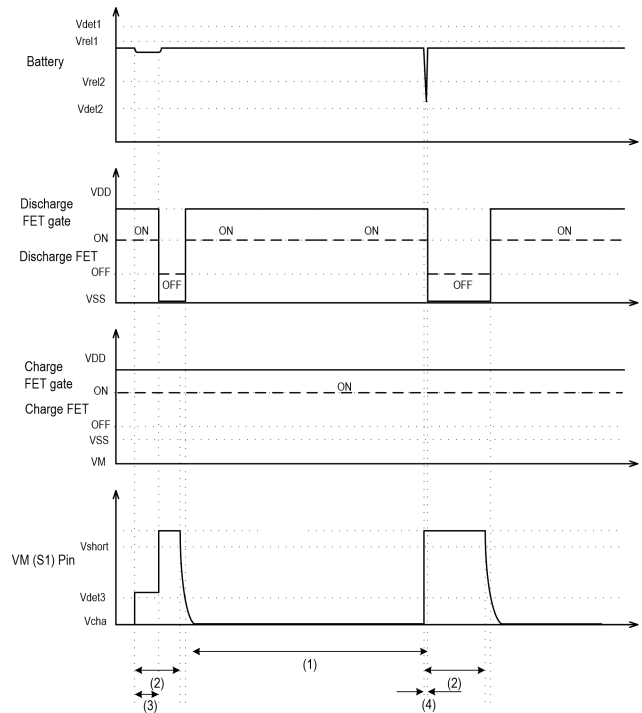

- (1) Normal condition
- (2) Load connection
- (3) Discharge Overcurrent Delay Time (Tvdet3)
- (4) Short Circuit Delay Time (Tshort)

**Operation Timing Chart (4)
Charger Connection Detection**

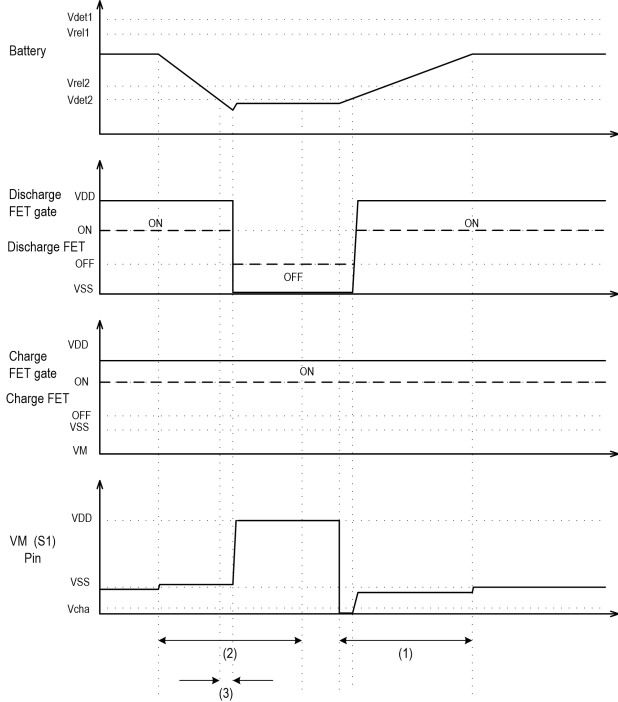

- (1) Charger connection
- (2) Load connection
- (3) Overdischarge Detection Delay (T_{vdet2})

**Operation Timing Chart (5)
Charge Overcurrent Detection**

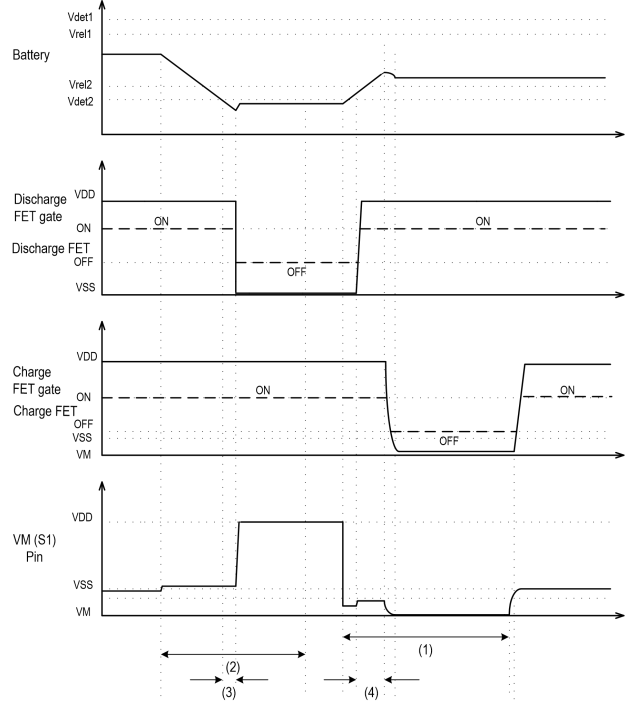

- (1) Charger connection
- (2) Load connection
- (3) Overdischarge Detection Delay Time (T_{vdet2})
- (4) Charge Overcurrent Detection Delay Time

Test Circuits

(1) Overcharge detection voltage and overcharge release voltage (Test circuit 1)

The Overcharge Detection Voltage (V_{det1}) is the voltage between V_{DD} and V_{SS} to which when V_1 increases and keeps the condition for overcharge delay time, The charging control FET turns off, V_{S1} is the threshold of a diode, The Overcharge Release Voltage (V_{rel1}) is the voltage between V_{DD} and V_{SS} to which when V_1 decreases, The charging control FET turns on, $V_{S1}=0V$.

(2) Overdischarge detection voltage and Overdischarge release voltage (Test circuit 1)

The Overdischarge Detection Voltage (V_{det2}) is the voltage between V_{DD} and V_{SS} to which when V_1 decreases and keep the condition for overdischarge delay time, The discharging control FET turns off, $V_{S1}=V_1$. The overdischarge Release Voltage (V_{rel2}) is the voltage between V_{DD} and V_{SS} to which when V_1 increases, The discharging control FET turns on, $V_{S1}=0V$.

(3) Discharge overcurrent detection voltage and short circuit detection voltage (Test circuit 2)

The Discharge Overcurrent Detection Voltage (V_{det3}) is the voltage between V_M and V_{SS} to which when V_M increases and keep the condition for Discharge Overcurrent Delay Time (T_{vdet3}), The discharging control FET turns off, $V_{S1}=V_1$.

The Short Circuit Detection Voltage (V_{short}) is the voltage between V_M and V_{SS} to which when V_M increases and keep the condition for Short Circuit Delay Time (T_{short}), The discharging control FET turns off, $V_{S1}=V_1$.

(4) Charger detection voltage and charge overcurrent detection voltage (Test circuit 2)

In the overdischarge condition, increase V_1 gradually until it is between V_{det2} and V_{rel2} . The voltage between V_M and V_{SS} to which when V_2 decreases, when the discharging control FET turns on, $V_{S1}=0V$, is the Charger Detection Voltage (V_{cha}).

In the normal charging condition, the voltage between V_M and V_{SS} to which when V_2 decreases, The charging control FET turns off, V_{S1} is the threshold of a diode, is the charge overcurrent detection voltage. It has the same value as the Charger Detection Voltage (V_{cha}).

(5) 0V battery charge starting charger voltage (Test circuit 2)

Set $V_1=V_2=0V$ and decrease V_2 gradually. The voltage between V_{DD} and V_M when the charging control FET turns on, V_{S1} is the threshold of a diode, is the 0V battery charge starting charger voltage.

(6) Normal operation current consumption and power down current consumption (Test circuit 2)

Set $V_1=3.9V$ and $V_2=0V$ under normal condition, the current I_{DD} flowing through V_{DD} pin is the normal operation consumption current (I_{DD}).

Set $V_1=3.9V$ and $V_2=0V$, let IC work in normal condition, set V_1 from 3.9V to 2.0V, then let V_M floating under overdischarge condition, the current I_{DD} flowing through V_{DD} pin is the power down current consumption ($I_{STANDBY}$).

(7) Overcharge detection (release) delay time and overdischarge detection (release) delay time (Test circuit 3)

If V1 increases to be V_{det1} or over V_{det1} and keeps the condition for some time, the charging control FET will turn off, V_{s1} is the threshold of a diode, The time is called overcharge detection delay time. It is used to judge whether overcharge happens indeed.

If V1 decreases from V_{det1} or over V_{det1} to below V_{rel1} , the charging control FET will turn on, $V_{s1}=0V$. The difference between this time and T_{reset} is called overcharge release delay time.

If V1 decreases to be V_{det2} or below V_{det2} and keeps the condition for some time, the discharging control FET will turn off, $V_{s1}=V1$. The time is called overdischarge detection delay time. It is used to judge whether overdischarge happens indeed.

If V1 increases from V_{det2} or below V_{det2} to over V_{rel2} and keeps the condition for some time, the discharging control FET will turn on, $V_{s1}=0V$. The time is called overdischarge release delay time.

(8) Discharge overcurrent detection delay time and short circuit detection delay time (Test circuit 4)

If V2 increases to be V_{det3} or over V_{det3} and keeps the condition for some time, the discharging control FET will turn off, $V_{s1}=V1$. The time is called Discharge Overcurrent Delay Time. It is used to judge whether Discharge Overcurrent happens indeed.

If V2 increases to be V_{short} or over V_{short} and keeps the condition for some time, the discharging control FET will turn off, $V_{s1}=V1$. The time is called short circuit delay time. It is used to judge whether short circuit happens indeed.

(9) Internal resistance $V_M - V_{DD}$ and $V_M - V_{SS}$ (Test circuit 4)

Set $V1=2.0V$, $V2=0V$, $V1/I_{VM}$ is the internal resistance R_{VMD} .

Set $V1=3.3V$, $V2=1V$, $V2/I_{VM}$ is the internal resistance R_{VMS} .

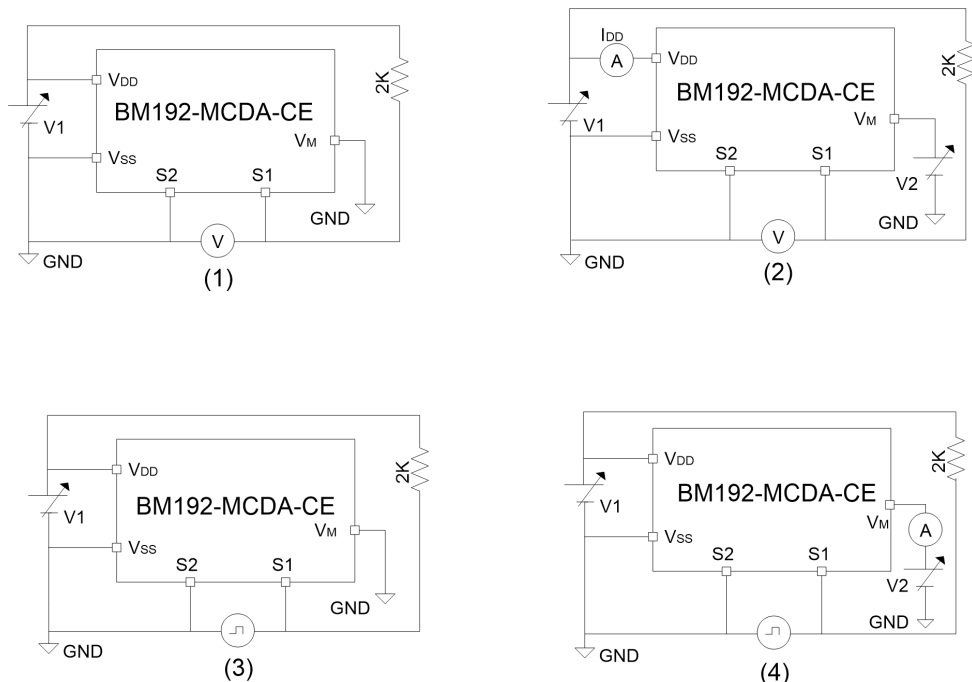

Package Outline

DFNWB 2.2*2.9-6L

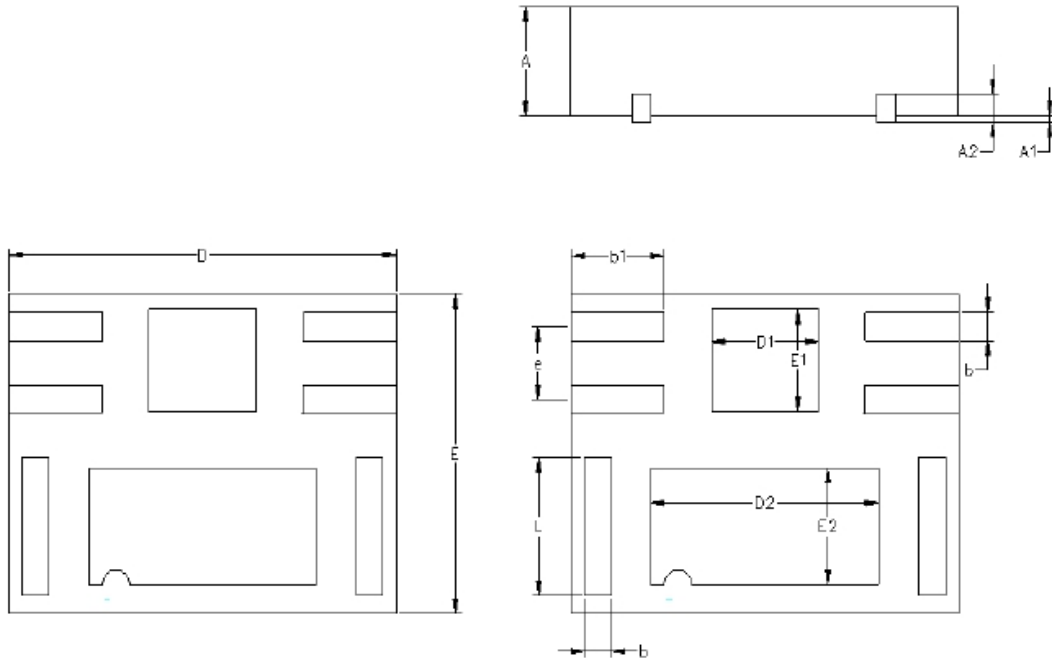

Dimensions (mm)

COMMON DIMENSIONS (mm)			
RER	MIN	NOM	MAX
A	0.70	0.75	0.80
A1	0.00		0.05
A2	0.20REF		
D	2.85	2.90	2.95
E	2.15	2.20	2.25
D1	0.75	0.80	0.85
E1	0.65	0.70	0.75
b	0.15	0.20	0.25
e	0.5BSC		
L	0.90	0.95	1.00
b1	0.65	0.70	0.75
D2	1.65	1.70	1.75
E2	0.75	0.80	0.85

Packing

MBB packing.7"reel: 3000pcs per reel.

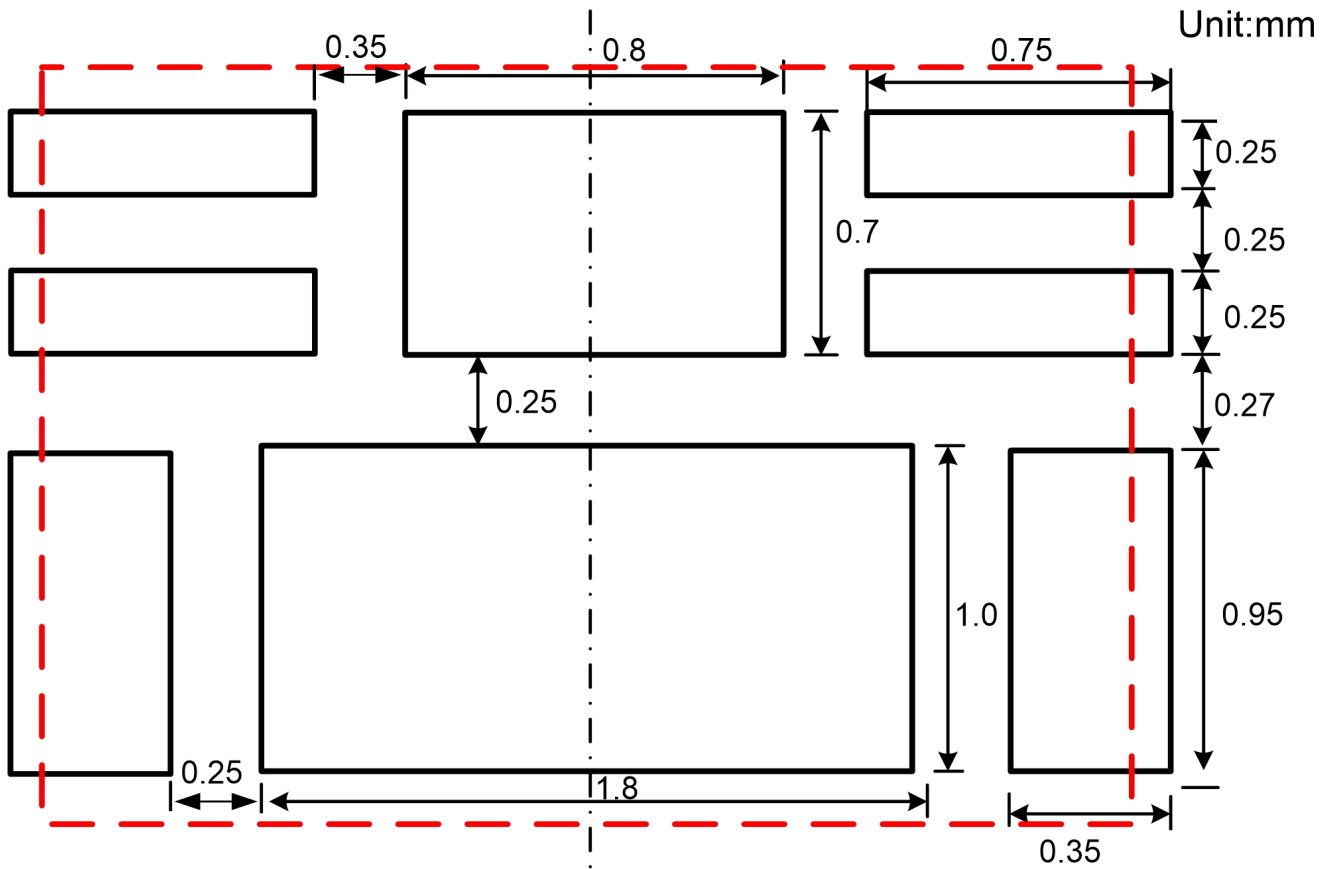
PCB Layout

**RESTRICTIONS ON PRODUCT USE**

- The information contained herein is subject to change without notice.

- **BYD Semiconductor Company Limited** exerts the greatest possible effort to ensure high quality and reliability. Nevertheless, semiconductor devices in general can malfunction or fail due to their inherent electrical sensitivity and vulnerability to physical stress. It is the responsibility of the buyer, when utilizing products, to comply with the standards of safety in making a safe design for the entire system, including redundancy, fire-prevention measures, and malfunction prevention, to prevent any accidents, fires, or community damage that may ensue. In developing your designs, please ensure that products are used within specified operating ranges as set forth in the most recent products specifications.

- The products listed in this document are intended for usage in general electronics applications (computer, personal equipment, office equipment, measuring equipment, industrial robotics, domestic appliances, etc.). These products are neither intended nor warranted for usage in equipment that requires extraordinarily high quality and/or reliability or a malfunction or failure of which may cause loss of human life or bodily injury (“Unintended Usage”). Unintended Usage include atomic energy control instruments, airplane or spaceship instruments, transportation instruments, traffic signal instruments, combustion control instruments, medical instruments, all types of safety devices, etc.. Unintended Usage of products listed in this document shall be made at the customer’s own risk.