



General Description

The BM3451-T20B-T28A is a professional protection IC for 3/4/5 cells rechargeable battery pack; it is highly integrated, and generally used in power tools, electric bicycle and UPS applications.

The BM3451-T20B-T28A works constantly to monitor each cell's voltage, the current of charge or discharge, and the temperature of the environment to provide overcharge, over-discharge, discharge overcurrent, short circuit, charge overcurrent and over-temperature protections, etc. Besides, it also can change the protection delay time of overcharge, over-discharge and discharge overcurrent by setting the external capacitors.

The BM3451-T20B-T28A provides external bleeding for cell-capacity balance function to avoid unbalanced capacity between each cell. Thus, the batteries can work for longer.

Extended function module embedded in the BM3451-T20B-T28A ICs can make them work for more battery packs with multiple chips, and they can protect 6-cell batteries or more than 6-cell batteries.

Features

(1) High-accuracy voltage detection for each cell

·overcharge threshold	3.6V~4.6V	accuracy: ± 25 mV (+25°C) accuracy: ± 40 mV (-40°C to +85°C)
·overcharge hysteresis	0.1V	accuracy: ± 50 mV
·over-discharge threshold	1.6V~3.0V	accuracy: ± 80 mV
·over-discharge hysteresis	0V / 0.2V / 0.4V	accuracy: ± 100 mV

(2) Three grades voltage detection of discharge overcurrent

·discharge overcurrent 1	0.025 V ~ 0.30 V (50 mV step)
·discharge overcurrent 2	0.2 V / 0.3V / 0.4V / 0.6 V
·short circuit	0.6V / 0.8V / 1.2 V

(3) Charge overcurrent detection

·detection voltage	-0.03V / -0.05V / -0.1V / -0.15V / -0.2 V
--------------------	---

(4) 3/4/5 cell protection enable

(5) Setting of output delay time

·overcharge, over-discharge, discharge overcurrent 1 and discharge overcurrent 2 protection delay time can be set by external capacitors

(6) Supports external bleeding for balance

(7) Controlling the state of charge or discharge by external signals

(8) The maximum output voltage of CO / DO: 12V

(9) Over-temperature protection

(10) Breaking wire protection

(11) Low power consumption

·operation mode (with Temp protection)	25 μ A	typical
·operation mode (without Temp protection)	15 μ A	typical
·sleeping mode	6 μ A	typical

Applications

- Power tool
- Electric bicycle
- UPS backup battery

Packages

- TSSOP28
- TSSOP20

Block Diagram

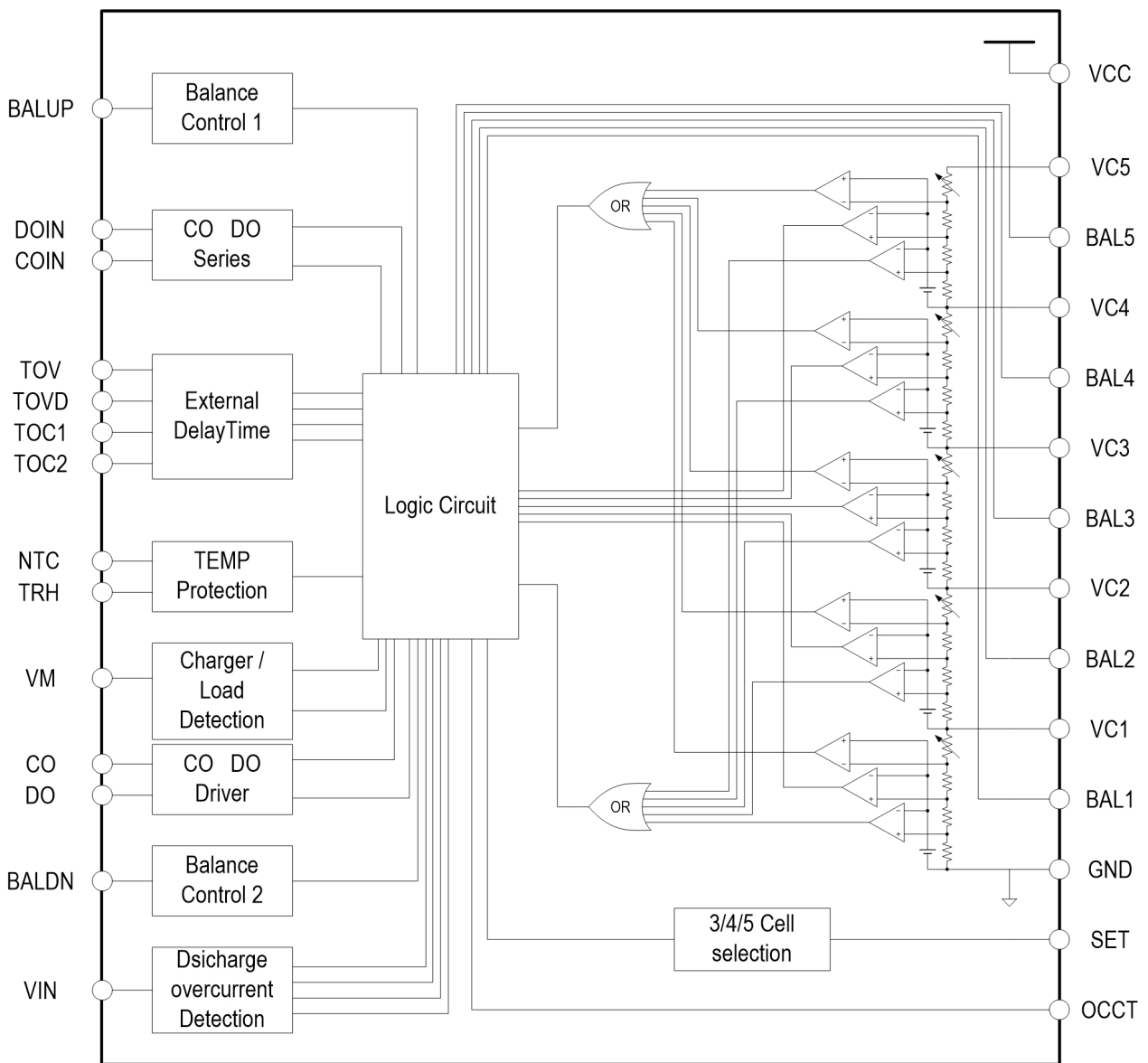

Figure 1

Selection Guides

1. Products name structure

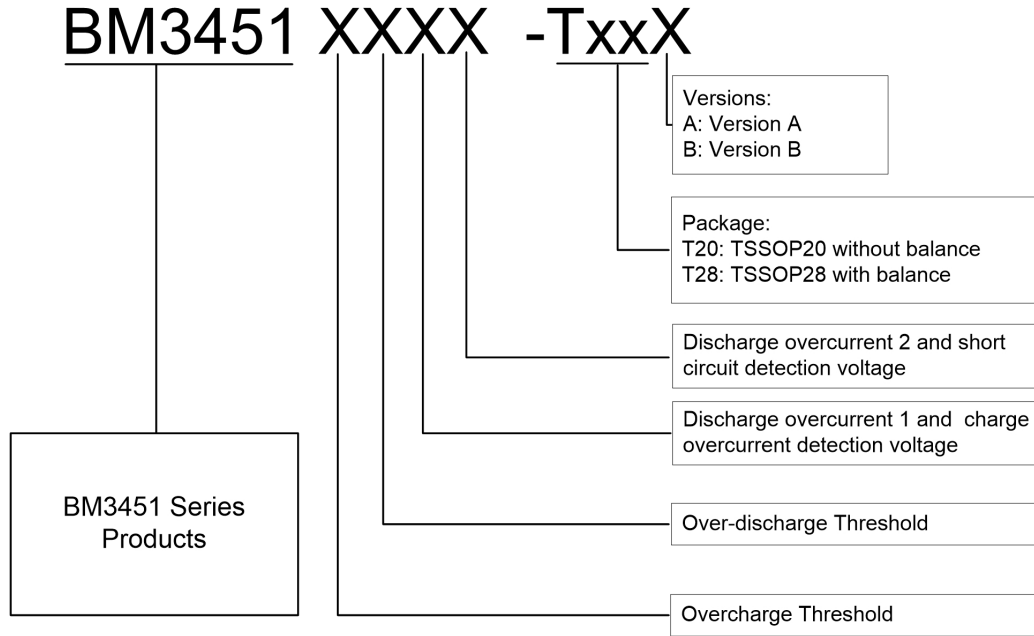

Figure 2

2. Products catalogue

Type/Item	Overcharge protection voltage [V _{DET1}]	Overcharge release voltage [V _{REL1}]	Over-discharge protection voltage [V _{DET2}]	Over-discharge release voltage [V _{REL2}]	Discharge overcurrent 1 detection voltage [V _{OC1}]	Discharge overcurrent 2 detection voltage [V _{OC2}]	Short circuit detection voltage [V _{SHORT}]	Charge overcurrent detection voltage [V _{OVCC}]	Balance detection voltage [V _{BAL}]
BM3451BFDC-T28A	3.650V	3.550V	2.000V	2.500V	0.100V	0.300V	0.600V	-0.100V	3.405V
BM3451BHDC-T28A	3.650V	3.550V	2.350V	2.550V	0.100V	0.300V	0.600V	-0.100V	3.405V
BM3451HEDC-T28A	3.850V	3.790V	2.000V	2.500V	0.100V	0.400V	0.800V	-0.050V	3.590V
BM3451UNDC-T28A	4.235V	4.175V	2.800V	3.000V	0.100V	0.400V	0.800V	-0.050V	4.180V
BM3451TNDC-T28A	4.250V	4.190V	2.800V	3.000V	0.100V	0.400V	0.800V	-0.050V	4.190V
BM3451TJDC-T28A	4.250V	4.190V	2.500V	2.700V	0.100V	0.400V	0.800V	-0.050V	4.190V
BM3451VJDC-T28A	4.300V	4.240V	2.500V	2.700V	0.100V	0.400V	0.800V	-0.050V	4.240V
BM3451SMDC-T28A	4.225V	4.165V	2.750V	3.000V	0.100V	0.400V	0.800V	-0.050V	4.165V
BM3451XKDC-T28A	4.350V	4.290V	2.600V	2.850V	0.100V	0.400V	0.800V	-0.050V	4.290V
BM3451HEDC-T20B	3.850V	3.750V	2.000V	2.500V	0.100V	0.400V	0.800V	-0.050V	-
BM3451SMDC-T20B	4.225V	4.105V	2.750V	3.000V	0.100V	0.400V	0.800V	-0.050V	-
BM3451TNDC-T20B	4.250V	4.130V	2.800V	3.000V	0.100V	0.400V	0.800V	-0.050V	-
BM3451TJDC-T20B	4.250V	4.130V	2.500V	2.700V	0.100V	0.400V	0.800V	-0.050V	-

**BM3451-T20B-T28A**

BM3451VJDC-T20B	4.300V	4.180V	2.500V	2.700V	0.100V	0.400V	0.800V	-0.050V	-
BM3451RMDC-T20B	4.200V	4.080V	2.750V	3.000V	0.100V	0.400V	0.800V	-0.050V	-
BM3451XJDC-T20B	4.350V	4.230V	2.500V	2.800V	0.100V	0.400V	0.800V	-0.050V	-
BM3451YNDC-T20B	4.375V	4.255V	2.850V	3.100V	0.100V	0.400V	0.800V	-0.050V	-
BM3451ZKDC-T20B	4.425V	4.305V	2.650V	2.950V	0.100V	0.300V	0.600V	-0.050V	-
BM3451QMDC-T20B	4.175V	4.055V	2.750V	3.000V	0.100V	0.400V	0.800V	-0.050V	-

Table 1

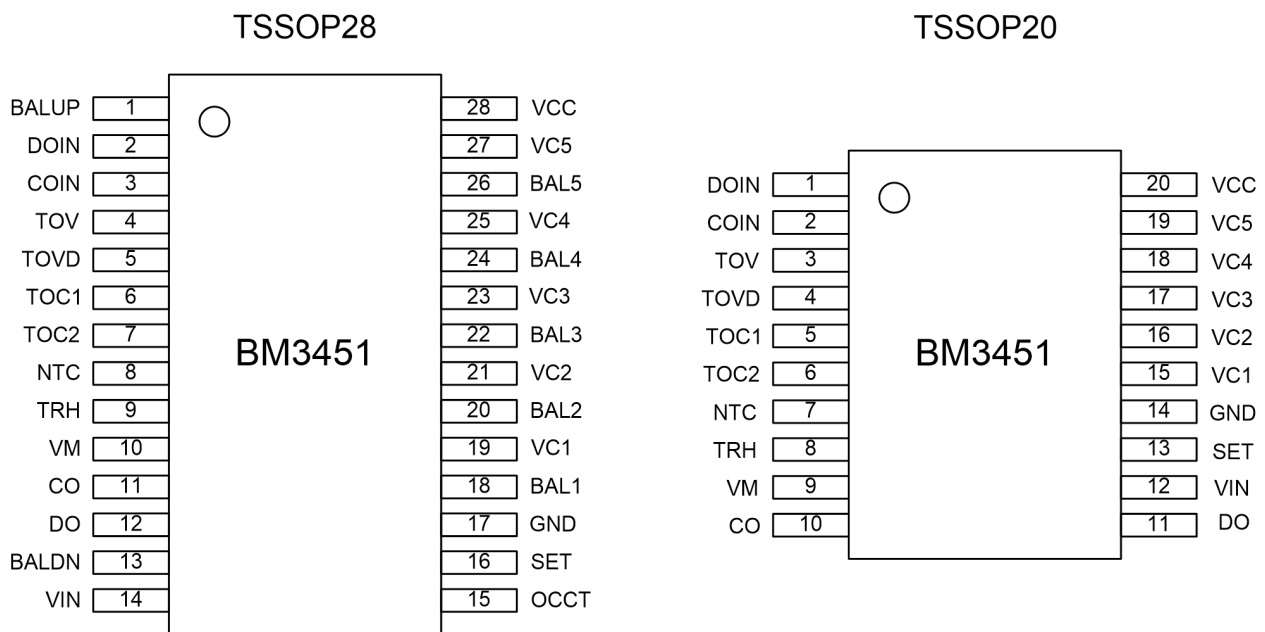
Pin Configurations

Top View

Figure 3

Pin Definition

TSSOP28 Pin number	TSSOP20 Pin number	Name	Description
1	-	BALUP	Balance signal transfer terminal 1
2	1	DOIN	DO controller for extended application
3	2	COIN	CO controller for extended application
4	3	TOV	Connect to a capacitor for setting the delay time of overcharge protection
5	4	TOVD	Connect to a capacitor for setting the delay time of over-discharge protection
6	5	TOC1	Connect to a capacitor for setting the delay time of discharge overcurrent 1 protection



7	6	TOC2	Connect to a capacitor for setting the delay time of discharge overcurrent 2 protection
8	7	NTC	Cell temperature detection
9	8	TRH	Temperature protection reference
10	9	VM	Voltage detection terminal 1 for detecting load or charger
11	10	CO	Charge power MOSFET control terminal, Open-Drain output
12	11	DO	Discharge power MOSFET control terminal, CMOS output
13	-	BALDN	Balance signal transfer terminal 2
14	12	VIN	Charge and Discharge overcurrent Voltage detection terminal 2
15	-	OCCT	Discharge overcurrent release control terminal by load
16	13	SET	Select terminal for 3/4/5 cell application
17	14	GND	Ground pin of the IC, Cell1 negative input
18	-	BAL1	Cell1 external bleeding control
19	15	VC1	Cell1 positive input, Cell2 negative input
20	-	BAL2	Cell2 external bleeding control
21	16	VC2	Cell2 positive input, Cell3 negative input
22	-	BAL3	Cell3 external bleeding control
23	17	VC3	Cell3 positive input, Cell4 negative input
24	-	BAL4	Cell4 external bleeding control
25	18	VC4	Cell4 positive input, Cell5 negative input
26	-	BAL5	Cell5 external bleeding control
27	19	VC5	Cell5 positive input
28	20	VCC	Power supply, Cell5 positive input

Table 2

Absolute Maximum Ratings

Item	Symbol	Description	Ratings	Unit
Power supply voltage	VCC	-	GND-0.3 ~ GND+30	V
Single cell input voltage	V _{CELL}	V _{cell5} , V _{cell4} , V _{cell3} V _{cell2} , V _{cell1}	GND-0.3 ~ GND+6	V
VM input voltage	VM	VM	GND-20 ~ GND+30	V
DO output voltage	V _{DO}	DO	GND-0.3 ~ VCC+0.3	V
CO output voltage	V _{CO}	CO	GND-20 ~ VCC+0.3	V
Operating temperature	T _A	-	-40 ~ +85	°C
Storage temperature	T _{STG}	-	-40 ~ +125	°C
ESD rating	V _{ESD}	HBM	±2000	V

Table 3



Caution: The absolute maximum ratings are rated values exceeding which the product could suffer physical damage. These values must therefore not be exceeded in any conditions

Electrical Characteristics(T_A=25°C unless otherwise specified)

Item	Symbol	Test conditions*1	Min.	Typ.	Max.	Unit	Test circuit
Power supply voltage	VCC	-	5	-	30	V	1
Operating consumption	I _{CC}	V1=V2=V3=V4=V5=3.5V	-	15	25	μA	
VC5 consumption	I _{VC5}	V1=V2=V3=V4=V5=3.5V	-	3	6	μA	
Sleeping consumption	I _{SLP}	V1=V2=V3=V4=V5=2.0V	-	6	10	μA	
Overcharge	Protection threshold	V _{DET1} V1=V2=V3=V4=3.5V V5=3.5→4.4V	V _{DET1} -0.025	V _{DET1}	V _{DET1} +0.025	V	2
	Protection delay time	T _{OV} V1=V2=V3=V4=3.5V C _{OV} =0.1μF V5=3.5V→4.4V	0.5	1.0	1.5	s	
	Release threshold	V _{REL1} V1=V2=V3=V4=3.5V V5=4.4V→3.5V	V _{REL1} -0.05	V _{REL1}	V _{REL1} +0.05	V	
	Release delay time	T _{REL1} V1=V2=V3=V4=3.5V V5=4.4V→3.5V	10	20	30	ms	
	Temperature factor(1)	K _{U1} T _a = -40°C to 85°C	-0.6	0	0.6	mV/°C	
	Reset time	T _{RESET}	-	5	10	15	
Over-discharge	Protection threshold	V _{DET2} V1=V2=V3=V4=3.5V V5=3.5V→2.0V	V _{DET2} -0.08	V _{DET2}	V _{DET2} +0.08	V	3
	Protection delay time	T _{OVD} V1=V2=V3=V4=3.5V C _{OVD} =0.1μF V5=3.5V→2.0V	0.5	1.0	1.5	s	
	Release threshold	V _{REL2} V1=V2=V3=V4=3.5V V5=2.0V→3.5V	V _{REL2} -0.10	V _{REL2}	V _{REL2} +0.10	V	
	Release delay time	T _{REL2} V1=V2=V3=V4=3.5V V5=2.0V→3.5V	10	20	30	ms	
Discharge overcurrent 1	Protection threshold	V _{OC1} V1=V2=V3=V4=V5=3.5V V6=0V→0.12V	V _{OC1} *85%	V _{OC1}	V _{OC1} *115%	V	3
	Protection delay time	T _{OC1} V1=V2=V3=V4=V5=3.5V C _{OC1} =0.1μF V6=0V→0.12V	100	200	300	ms	
	Release delay time	T _{ROC1} V1=V2=V3=V4=V5=3.5V V6=0V→0.12V→0V	100	200	300	ms	



	Resistance between VM and GND	R_{VMS}	$V1=V2=V3=V4=V5=3.5V$ $V6=0V \rightarrow 0.12V$	100	300	500	k Ω	
	Temperature factor(2)	K_{U2}	$T_a = -40^{\circ}C$ to $85^{\circ}C$	-0.1	0	0.1	mV/ $^{\circ}C$	
Discharge overcurrent 2	Protection threshold	V_{OC2}	$V1=V2=V3=V4=V5=3.5V$ $V6=0V \rightarrow 0.5V$	V_{OC2} *80%	V_{OC2}	V_{OC2} *120%	V	
	Protection delay time	T_{OC2}	$V1=V2=V3=V4=V5=3.5V$ $C_{OC2}=0.1\mu F$ $V6=0V \rightarrow 0.5V$	10	20	30	ms	
Short circuit	Protection threshold	V_{SHORT}	$V1=V2=V3=V4=V5=3.5V$ $V6=0V \rightarrow 1.2V$	V_{SHORT} *80%	V_{SHORT}	V_{SHORT} *120%	V	3
	Protection delay time	T_{SHORT}	$V1=V2=V3=V4=V5=3.5V$ $V6=0V \rightarrow 1.2V \rightarrow 0V$	100	300	600	μs	
Charge overcurrent	Protection threshold	V_{OVCC}	$V1=V2=V3=V4=V5=3.5V$ $V6=0V \rightarrow -0.2V$	V_{OVCC} -0.015	V_{OVCC}	V_{OVCC} +0.015	V	4
	Protection delay time	T_{OVCC}	$V1=V2=V3=V4=V5=3.5V$ $V6=0V \rightarrow -0.2V$	10	20	30	ms	
External bleeding voltage for balance		V_{BAL}	$V1=V2=V3=V4=3.5V$ $V5=3.5V \rightarrow 4.30V$	V_{BAL} -0.05	V_{BAL}	V_{BAL} +0.05	V	5
Output resistances	CO	R_{CO}	Normal time, Co "H" (12V)	3	5	8	k Ω	6
	DO	R_{DO}	Normal time, Do "H" (12V)	3	5	8	k Ω	7
			Protecting time, Do "L"	0.20	0.35	0.50		
	BAL1	R_{BAL1}	On "H"	1.4	2.0	2.6	k Ω	8
			Off "L"	0.5	0.8	1.1		
	BAL2	R_{BAL2}	On "H"	1.4	2.0	2.6		
			Off "L"	0.5	0.8	1.1		
	BAL3	R_{BAL3}	On "H"	1.4	2.0	2.6		
			Off "L"	0.5	0.8	1.1		
	BAL4	R_{BAL4}	On "H"	1.4	2.0	2.6		
Off "L"			0.5	0.8	1.1			
BAL5	R_{BAL5}	On "H"	1.4	2.0	2.6			
		Off "L"	0.5	0.8	1.5			

Table 4

*1: All the test condition parameters above are designed based on Li+ parameters, other grade parameters can adjust by their own actual voltages. The protection delay time above does not include capacitance error, it is recommend to select a higher accuracy capacitance within $\pm 5\%$.



Function Description

1. Overcharge

During charging, $V_{IN} > V_{OVCC}$ when IC doesn't work in the state of charge overcurrent, If any of VC1, (VC2-VC1), (VC3-VC2), (VC4-VC3) and (VC5-VC4) is higher than V_{DET1} and lasts longer than T_{OV} , BM3451 chip considers that the batteries work in the state of overcharge, the output voltage of CO will become to high resistance from high level, and then it will be pulled down to low level by external resistor. The charge MOSFET will be turned off and stop charging.

The overcharge protection state will be released if any of the next conditions occurs:

- (1) All cells' voltage is less than the Overcharge release threshold V_{REL1} and stays a period of time T_{REL1} .
- (2) $V_M > 100mV$ (connecting to the load), Battery voltage is lower than V_{DET1} and stays a period of time T_{REL1} .

2. Over-discharge

During discharging, $V_{IN} < V_{OVCC}$ when IC doesn't work in the state of discharge overcurrent. If any of VC1, (VC2-VC1), (VC3-VC2), (VC4-VC3) and (VC5-VC4) is less than V_{DET2} and lasts longer than T_{OVD} . BM3451 chip considers that the batteries work in the state of over-discharge and the output voltage of DO will turn to GND. The discharge MOSFET will be turned off and stop discharging, then the chip will enter sleeping mode.

The over-discharge protection state will be released if any of the next conditions occurs:

- (1) $V_M = 0mV$, all cells' voltage is higher than V_{REL2} and stays a period of time T_{REL2} .
- (2) $V_M < -100mV$ (connecting to the charger), all cells' voltage is higher than V_{DET2} and stays a period of time T_{REL2} .

3. Discharge overcurrent

During discharging, the current varies with the load. The voltage of V_{IN} becomes higher with the current increasing. When the voltage of V_{IN} is higher than V_{OC1} and stays longer than T_{OC1} , we think the IC works in the state of discharge overcurrent 1; When the voltage of V_{IN} is higher than V_{OC2} and stays longer than T_{OC2} , we consider the IC works in the state of discharge overcurrent 2; When the voltage of V_{IN} is higher than V_{SHORT} and stays longer than T_{SHORT} , we think the IC works in the state of short circuit. When any of the three states occurs, the output voltage of DO changes to low level to turn off the discharge MOSFET and stop discharging. At the same time, R_{VMS} which is the inner pulling down resistance of V_M is connected, and we know that V_M is pad which we can lock the output voltage of DO by when chip works in the state of overcurrent discharge. Usually $V_{OC1} < V_{OC2} < V_{SHORT}$, $T_{OC1} > T_{OC2} > T_{SHORT}$. When IC works in discharge overcurrent, the output voltage of DO is locked in low level. The discharge overcurrent protection state will be released when disconnect the load.

4. Delay Time Setting

Overcharge and Over-discharge delay time can be calculated as follow:

$$T_{ov} = 10^7 \times C_{OV}; T_{ovd} = 10^7 \times C_{OVD}$$



Discharge overcurrent 1 delay time can be calculated as follow: $T_{oc1} = 2 \times 10^6 \times C_{OC1}$

Discharge overcurrent 2 delay time can be calculated as follow: $T_{oc2} = 2 \times 10^5 \times C_{OC2}$

5. Charge overcurrent

During charging, if the current is biggish with $V_{IN} < V_{OVCC}$ and stays longer than T_{OVCC} , the BM3451 chip considers that the batteries work in the state of charge overcurrent, the output voltage of CO will be pulled down to low level and the charge MOSFET will be turned off and stop charging. Charge overcurrent protection will be released when we disconnect the charger.

6. Balance Function

Cells' balance function is used to balance the cells' capacity in a pack. When all voltages of VC1, (VC2-VC1), (VC3-VC2), (VC4-VC3) and (VC5-VC4) are lower or higher than V_{BAL} , all the external balance discharge circuits will not work. Otherwise the cell, whose voltage is higher than V_{BAL} , will turn on the external discharge circuit and make its voltage lower than V_{BAL} . During charging, If the highest voltage of five cells enters overcharge state and its cell balance circuit turns on, the charge control MOSFET turns off and the external discharge circuit works and makes the battery voltage fall down to V_{REL1} which is the overcharge release threshold, then turn on the charge control MOSFET for continuing charge. For a long enough time of charge and discharge cycles, the voltages of all cells will reach to more than V_{BAL} , and avoid the capacity differences between batteries.

7. Over-temperature

Usually, batteries should be prevented charging and discharging from over-temperature. The BM3451 chip has this over-temperature protection. During over-temperature detecting, the BM3451 considers discharge state acquiescently, only when $V_M < -100mV$, the BM3451 considers charge state. The thermostat resistor connecting to NTC pad is used to induct the pack's temperature, the resistor connecting TRH pad is used to set the reference of over-temperature protection. Assuming the resistance of NTC is R_{NTC} when the pack gets to the temperature of charge over-temperature protection, and then we set the resistance R_{TRH} of TRH be $R_{TRH} = 2 * R_{NTC}$. The over-discharge protection temperature is the temperature when the resistance of NTC become to $0.54 * R_{NTC}$. We can set the temperature of charge and discharge protection by changing the value of R_{TRH} .

Take 103AT-4 for example, NTC resistance is 10KΩ in normal temperature (25°C), and the temperature of charge over-temperature protection is 55°C. When the temperature is 55°C and chip works in the state of charging, R_{NTC} is 3.5KΩ, so R_{TRH} is equal to 7KΩ. We also know the NTC resistance is $0.54 * R_{NTC} = 1.89 KΩ$ when the pack arrive to the temperature of discharge over-temperature, the temperature is 75°C in this condition. The hysteresial temperature of charge over-temperature is 5°C and the hysteresial temperature of discharge over-temperature is 15°C. During charging, when the temperature is higher than 55°C, the output voltage of CO turns to high resistance, and will be pulled down to low level by external resistor, charge control MOSFET will be turned off and stops charging. And when the pack's temperature falls down to 50°C, CO changes to high level and charge control MOSFET be turned on again. During discharging, when the temperature is higher than 75°C, the output voltage of DO becomes to low level, discharge control MOSFET will be turned off and stop discharging, at the same time charge control MOSFET will also be turned off and stops charging. When pack's temperature falls down to 60°C, the output of CO and DO turn to high level, charge and discharge control MOSFET will both be turned on again.



8. Breaking wire protection

When one or multi wires of VC1, VC2, VC3, VC4 and VC5 are detected cut from the batteries by the BM3451 chip, the IC will consider it enters a state of breaking wire, then CO will be in high resistance and DO will turn to GND level, then the IC enters low consumption state.

When the breaking wires are connected correctly again, the IC will exit breaking wire protection. Specially attention, regardless one chip application or multi-chip application, the GND pin must not be open from the battery, or the IC cannot operate normally, and it cannot protect correctly.

9. 3/4/5 cells application selection

SET voltage	Cells	Short pins
Floating	5	-
VCC	4	VC1=GND
GND	3	VC1=VC2=GND

Chart 5

10. Extended application

When the BM3451 chip is used in extended condition, each IC transfers its information of overcharge, over-discharge, and balance to neighboring ICs. Take application of figure 6 for example, the information of DO and CO of IC1 will transfer to DOIN and COIN of IC2, then IC2 control external MOSFETs turn on or turn off by the voltage of DOIN and COIN. DOIN and COIN have precedence to control DO and CO over internal protection signals. Balance information transfer by BALUP and BALDN, IC follows the rule that inner balance has precedence over external balance.

Take extended application of three ICs with A, B, C for example, the external rule of balance is as follows:

A	B	C	Balance of A (ON or OFF)	Balance of B (ON or OFF)	Balance of C (ON or OFF)
0	0	0	OFF	OFF	OFF
0	0	1	OFF	OFF	ON
0	1	0	OFF	ON	OFF
0	1	1	OFF	ON	ON
1	0	0	ON	OFF	OFF
1	0	1	ON	OFF	ON
1	1	0	ON	ON	OFF
1	1	1	OFF	OFF	OFF

Signal descriptions: “1” shows that any of the batteries is equal to or above V_{BAL} , “0” shows that at least one of the batteries is lower than V_{BAL} .

Note: The charger detection of VM will shield DOIN signal, and the load detection of VM will shield COIN signal.

Operation Timing Charts

1. Overcharge/Over-discharge Protection

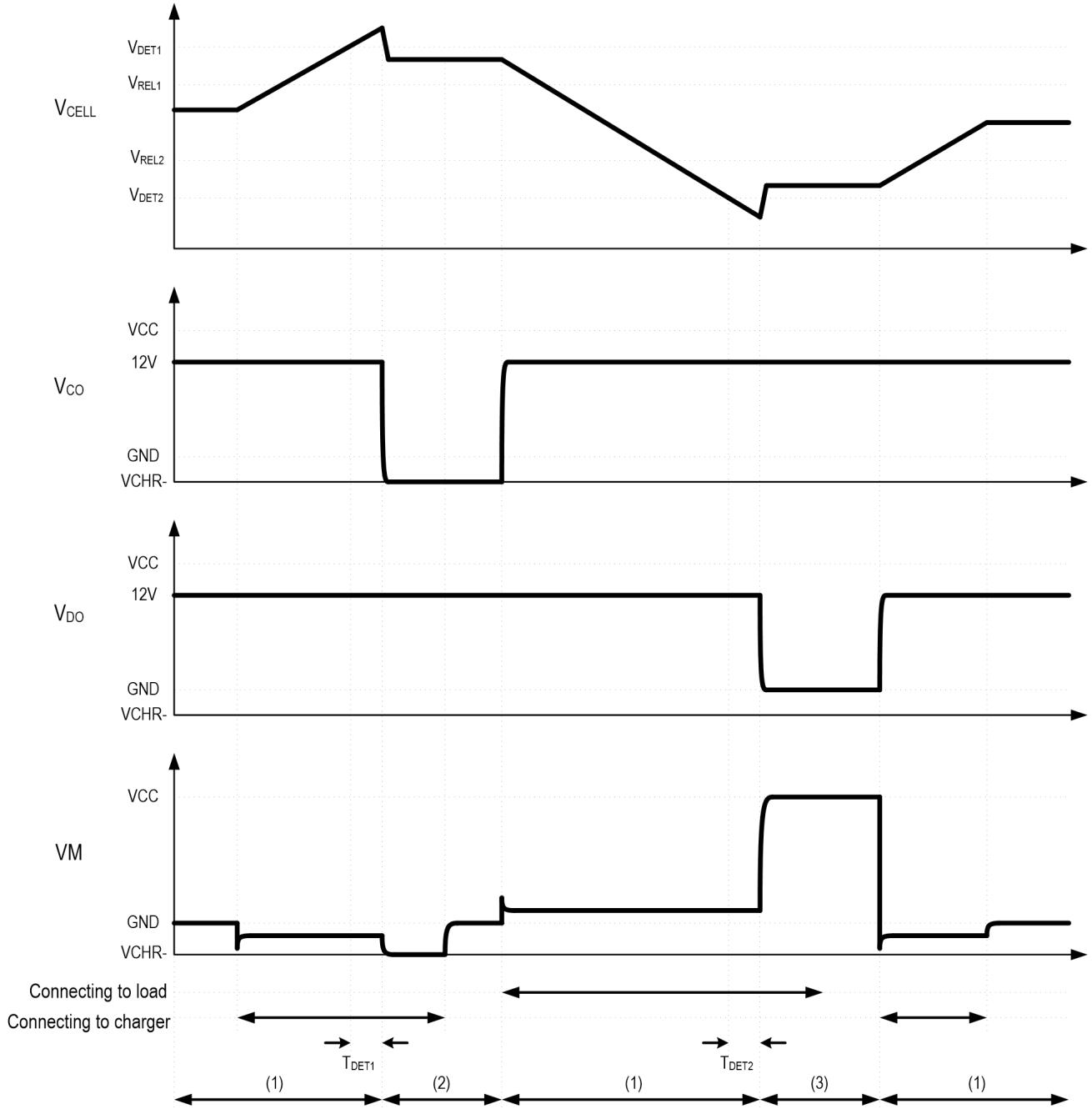

Figure 4

Assuming the charging current is constant, V_{CHR-} is the voltage of the charger's negative terminal:

- (1) Normal condition;
- (2) Overcharge protection state;
- (3) Over-discharge protection state.

2. Discharge overcurrent / Short Circuit / Charge overcurrent Protection

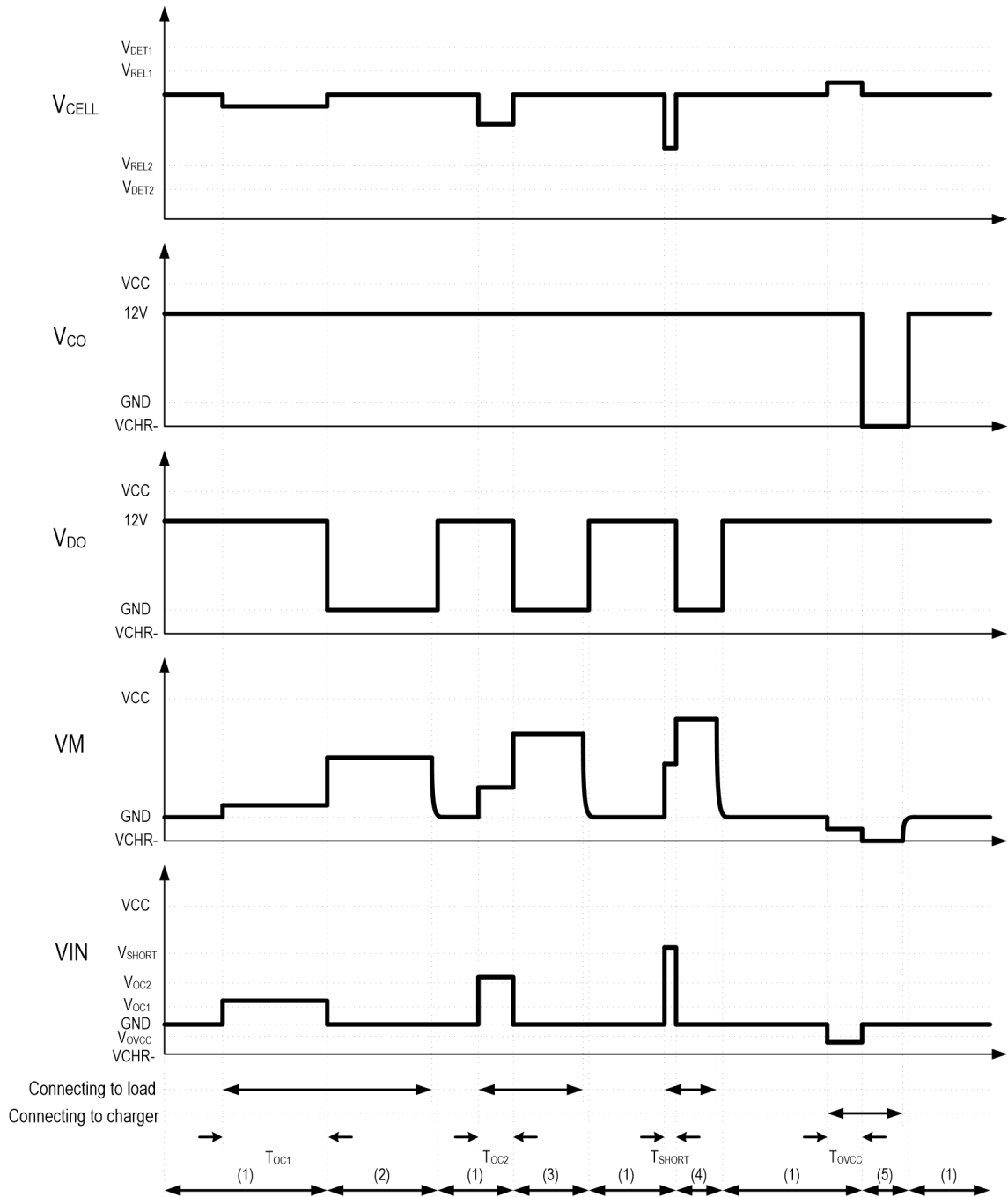

Figure 5

Assuming the charging current is constant, VCHR- is the voltage of the charger's negative terminal:

- (1) Normal condition;
- (2) Discharge overcurrent 1 protection state;
- (3) Discharge overcurrent 2 protection state;
- (4) Short circuit protection state;
- (5) Charge overcurrent protection state.

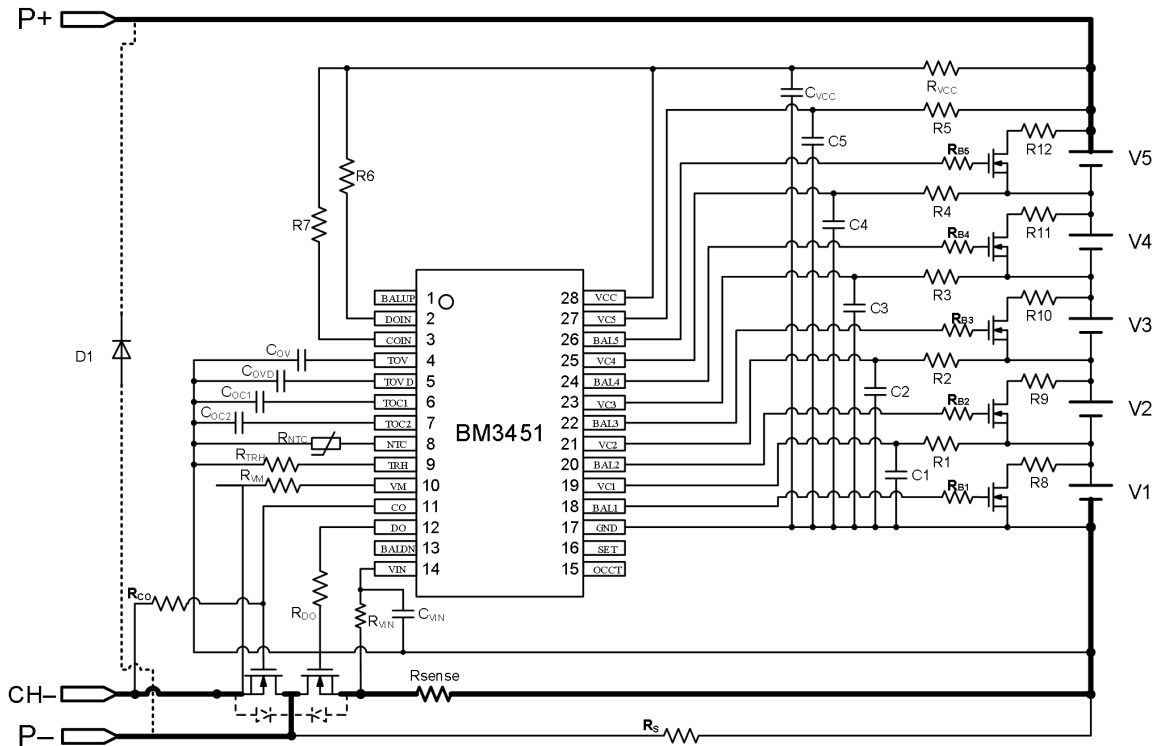

Figure 6 (a-2) 5-cell application (SET floating)
 ---with balance function, charge and discharge circuits separated

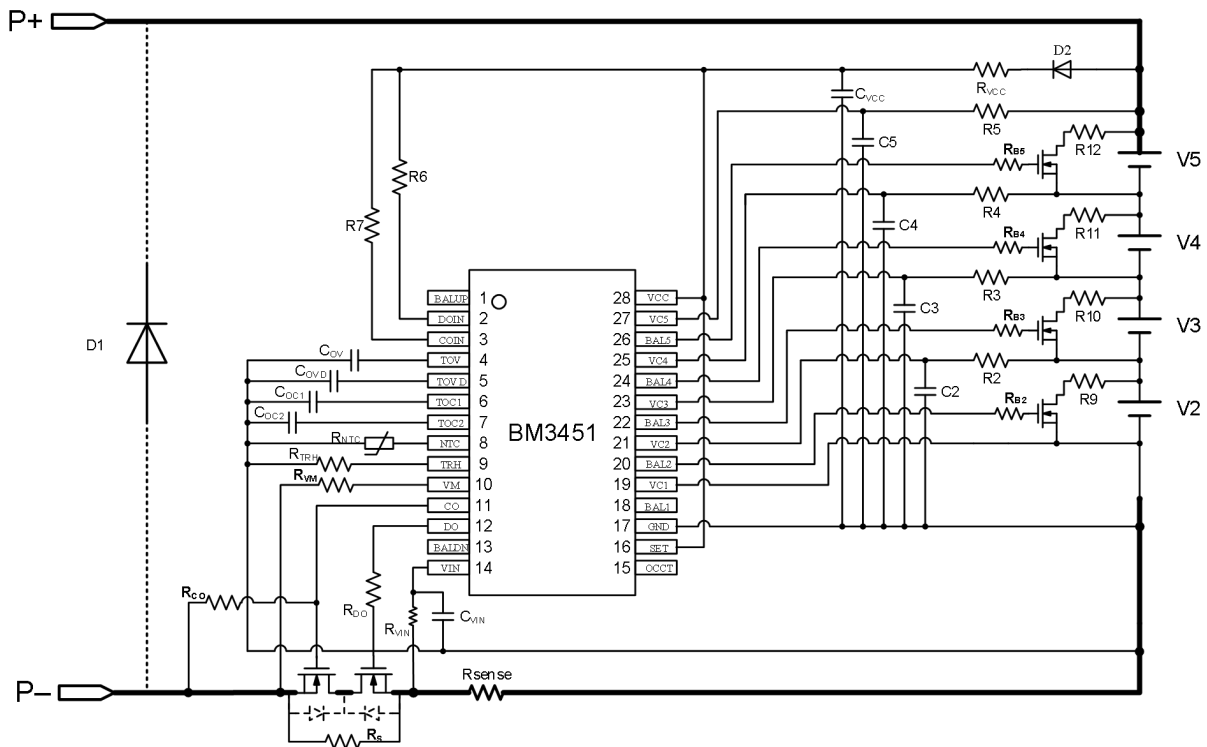

Figure 6 (b) 4-cell application (SET be connected to VCC) ---with balance function

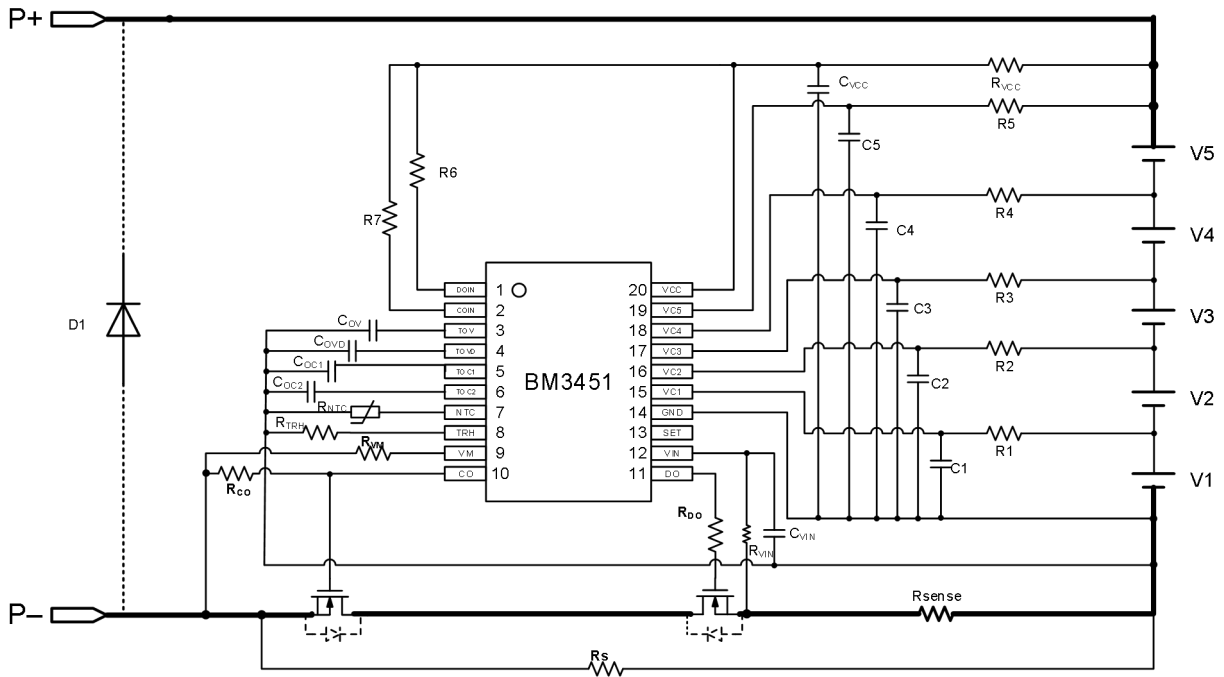

Figure 6 (d-1) 5-cell application (SET floating)
 ---without balance function, charge and discharge circuits together

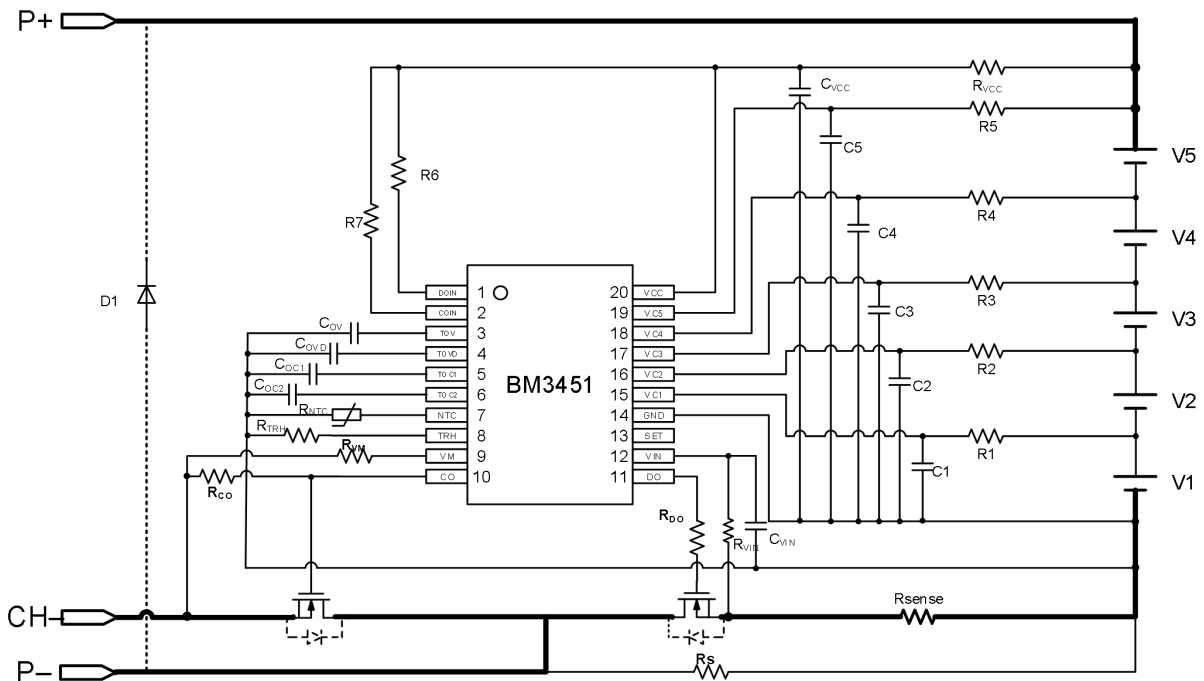

Figure 6 (d-2) 5-cell application (SET floating)
 ---without balance function, charge and discharge circuits separated

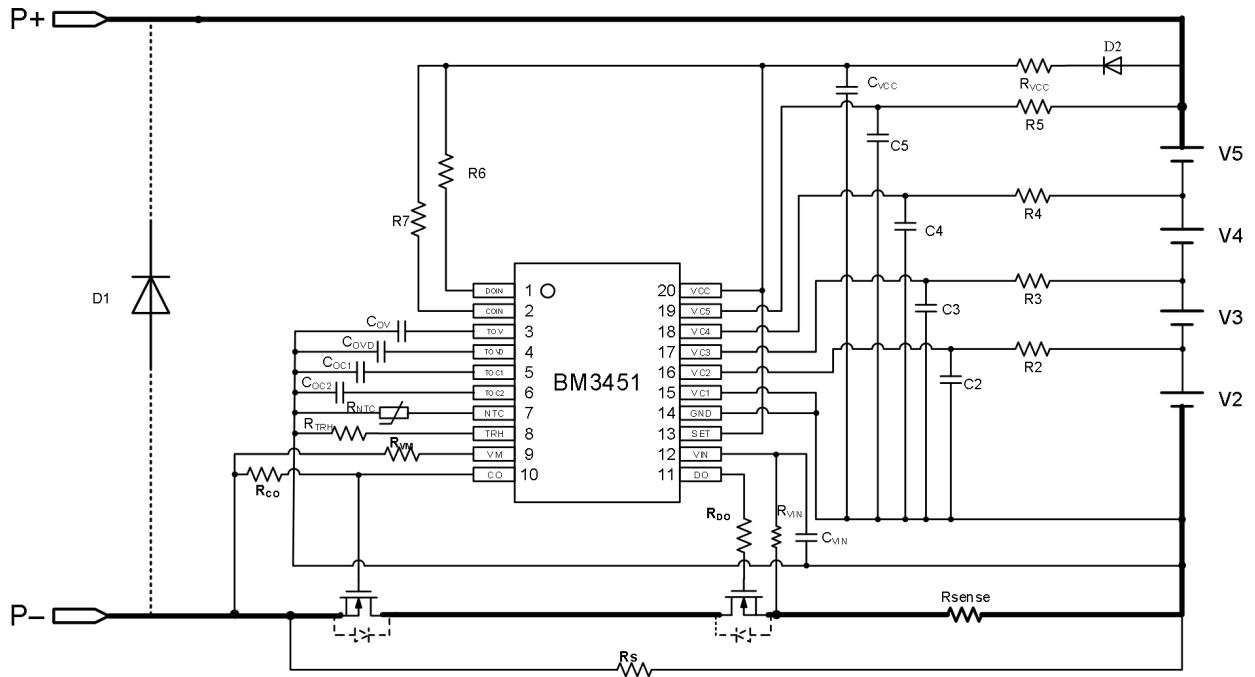

Figure 6 (e) **4-cell application (SET be connected to VCC) ---without balance function**

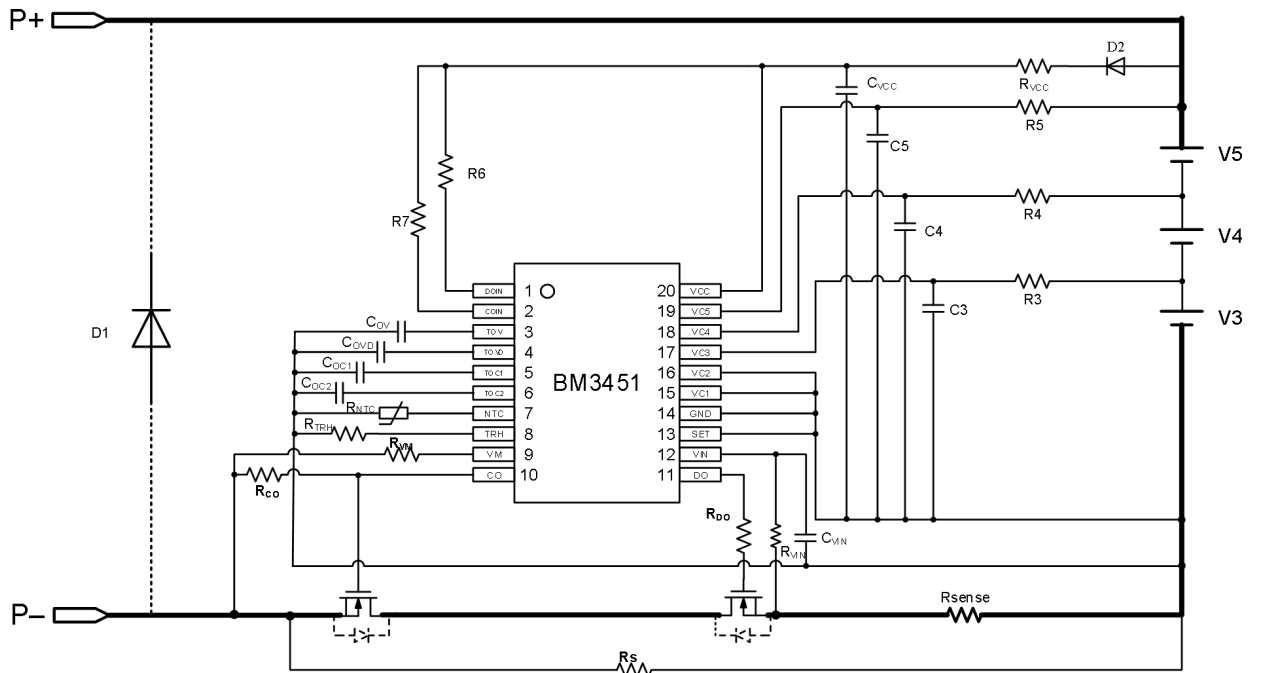
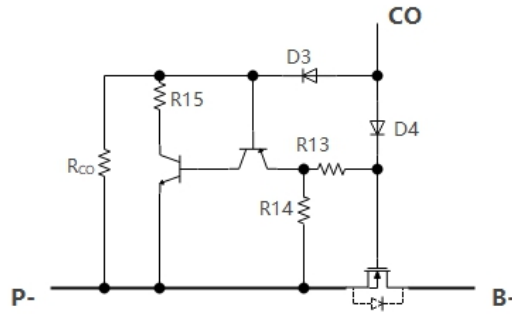
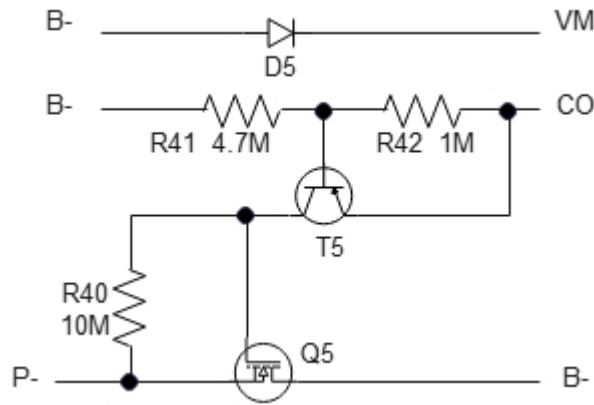

Figure 6 (f) **3-cell application (SET be connected to GND) ---without balance function**



To speed up the response of charge MOSFET, we recommend to add a fast pull-down circuit to CO pin.



It is recommended when the charge voltage is 20V higher than the total battery voltage.

Constants for External Components:

Component Symbol	Typ.	Range	Unit
R1, R2, R3, R4, R5	1000	100 ~ 1000	Ω
$R_{B1}, R_{B2}, R_{B3}, R_{B4}, R_{B5}$	4.7	3~10	M Ω
R_{VCC}	1000	100 ~ 1000	Ω
R6, R7, R13	1	1 ~ 2	M Ω
R8, R9, R10, R11, R12	47	10 ~ 200	Ω
R_{NTC}	10	-	k Ω
R_{TRH}	7	-	k Ω
R_{VM}	220	10-500	k Ω
$R_{CO}, R_S, R14$	10	5~15	M Ω
R_{DO}, R_{VIN}	2	1~10	k Ω
R15	100	-	k Ω
R_{sense}	5	1 ~ 20	m Ω
C_{VCC}	2.2	10 ~ 100	μF



BM3451-T20B-T28A

C1, C2, C3, C4, C5	1.0	0.1 ~ 10	Maximum endurable voltage >50V	μF
C _{OV} , C _{OV2} , C _{OC1} , C _{OC2}	0.1	-		μF
C _{VIN}	10	2.2~100		nF

Table 6

Note: When $R_s = 2M\Omega$, DO can recover automatically when the load is disconnected after over-discharge protection. When $R_s = 10M\Omega$, IC needs to be connected to the charge to activate after over-discharge protection and off load.

2. Two chips extended application

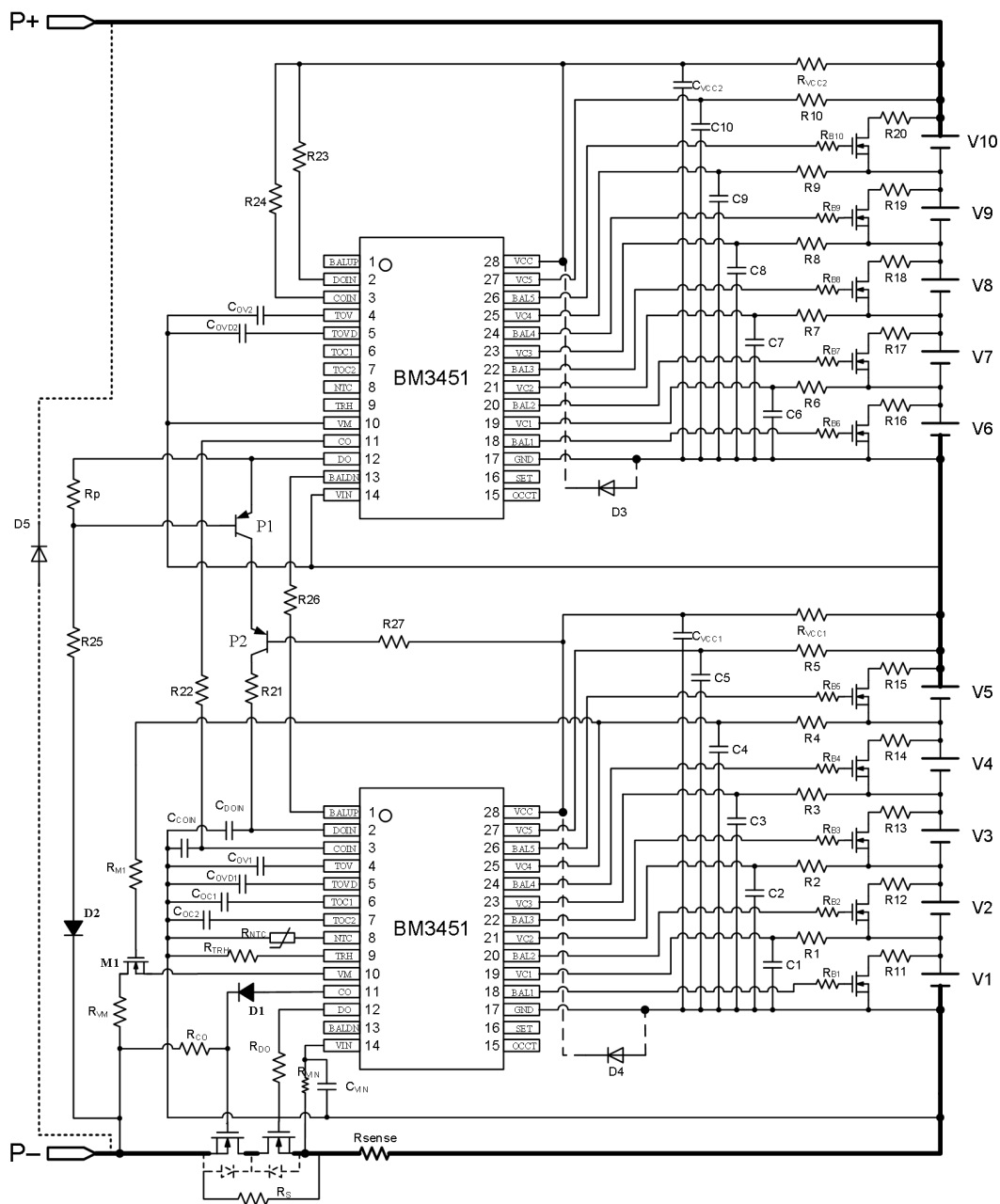

Figure 7 10-cell application——with balance function

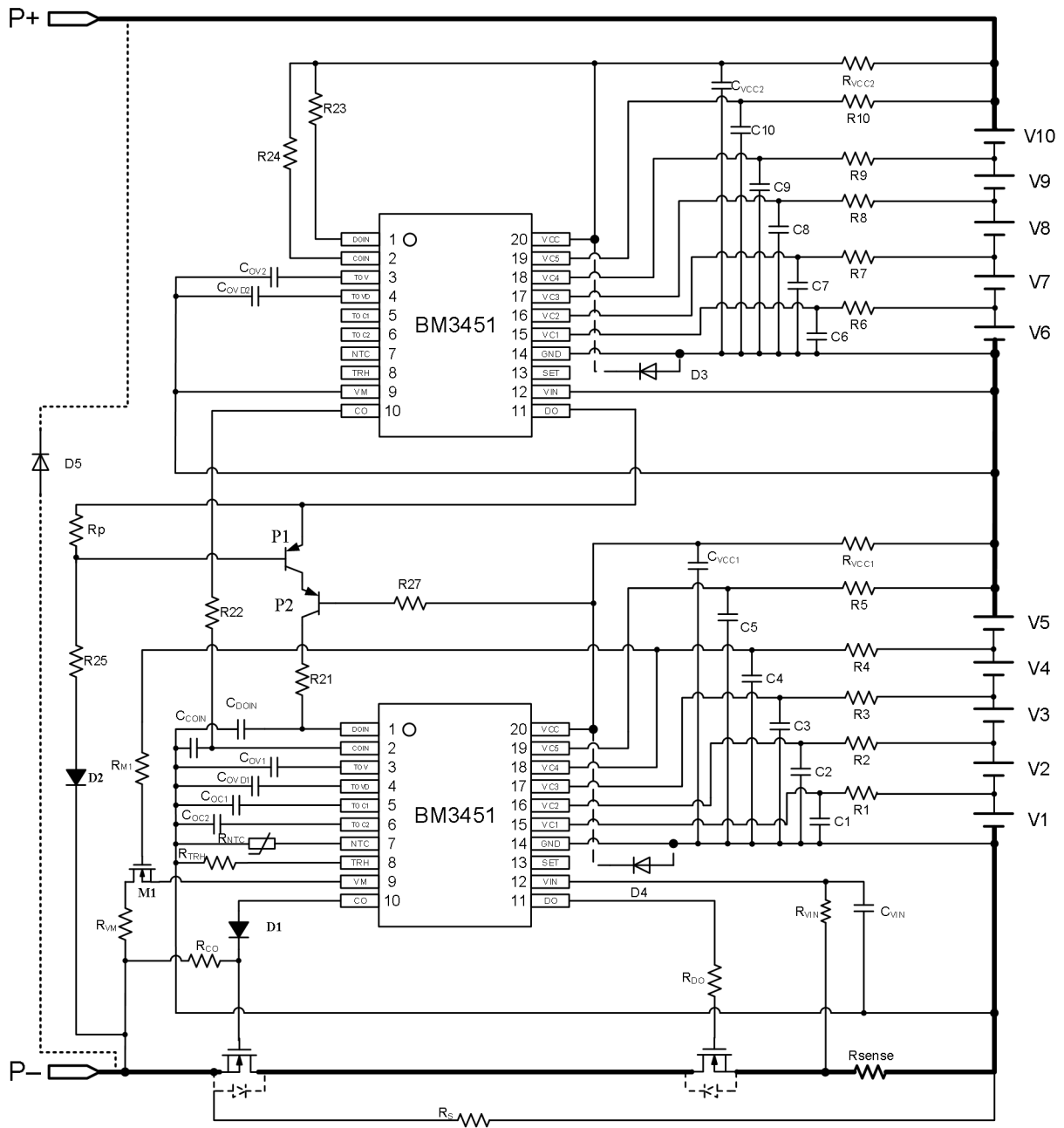

Figure 8 10-cell application——without balance function

Caution: The maximum endurable voltage of the MOS M1, the diode D1, D2 and the transistor P1 must be more than the total voltage of the whole battery packages, and keep enough voltage room. Above of 4-cell, 3-cell, and 10cell applications are charge and discharge circuits together, charge and discharge separated circuits can refer to 5-cell application.

Caution: The charger detection of VM will shield the signal transmission of DOIN and the load detection of VM will shield the signal transmission of COIN.

**Constants for External Components:**

Component Symbol	Typ.	Range	Unit
R1, R2, R3,R4, R5, R6,R7, R8, R9, R10	1000	100 ~ 1000	Ω
R _{B1} , R _{B2} , R _{B3} , R _{B4} , R _{B5} , R _{B6} , R _{B7} , R _{B8} , R _{B9} , R _{B10}	4.7	3 ~ 10	M Ω
R _{VCC1} , R _{VCC2}	1000	100 ~ 1000	Ω
R11, R12,R13, R14, R15, R16, R17, R18, R19, R20	47	10 ~ 200	Ω
R21	2	0 ~ 5	k Ω
R22, R25	10	8 ~ 15	M Ω
R23, R24, R _P	1	1 ~ 2	M Ω
R26	1	0~5	k Ω
R27	2	1~5	M Ω
R _{NTC1} , R _{NTC2}	10	-	k Ω
R _{TRH1} ,R _{TRH2}	7	-	k Ω
R _{VM}	200	10-500	k Ω
R _{CO} , R _S	10	5~15	M Ω
R _{DO}	2	0~10	k Ω
R _{sense}	5	0.1 ~ 20	m Ω
C _{VCC1} , C _{VCC2}	2.2	1 ~ 100	μ F
C1, C2, C3, C4, C5, C6, C7, C8, C9, C10	0.1	0 ~ 0.33	μ F
C _{OV1} , C _{OVD1} , C _{OV2} , C _{OVD2} , C _{OC1} , C _{OC2}	0.1	-	μ F
C _{DOIN} , C _{COIN}	33	33~100	nF
C _{VIN}	10	2.2~100	nF

Table 7

Note: When $R_S = 2M\Omega$, DO can recover automatically when the load is disconnected after over-discharge protection. When $R_S = 10M\Omega$, IC needs to be connected to the charge to activate after over-discharge protection and off load.

Test Circuits

The next tests take 5-cell application for example, so that SET pin is floating. If 4-cell application is selected, we set SET pin to VCC level and force GND voltage level to VC1; else if 3-cell application is selected, we set SET pin to GND level and force GND voltage level to VC1 and VC2. The test methods of 4-cell and 3-cell application are as same as 5-cell application.

1. Normal and Sleeping Current Consumption

Test circuit 1

- (1) Set $V1=V2=V3=V4=V5=3.50V$, the current flowing to GND is the normal operating current consumption.
- (2) On the condition of (1), then set $V1=V2=V3=V4=V5=2.0V$, the current flowing to GND is the sleeping current consumption.

2. Overcharge Protection Test

Test circuit 2

2.1 Overcharge threshold (V_{DET1}) and Overcharge release threshold (V_{REL1})

Set $V1=V2=V3=V4=V5=3.50V$, make sure the output voltages of DO and CO pins are “H” level. Increase $V5$ gradually, monitor CO voltage and keep the condition not shorter than T_{det1} , the value of $V5$ when CO turns from “H” to “L” is the overcharge threshold voltage. Decrease $V5$, the $V5$ when CO returns to “H” level again is the overcharge release threshold.

2.2 Overcharge protection delay time and Overcharge release delay time

- (1) Set $V1=V2=V3=V4=V5=3.50V$, make sure the output voltages of DO and CO pins are “H” level. Increase $V5$ to 4.4V from 3.5V instantaneously, monitor CO voltage and keep a period of time. The time interval when CO turns from “H” to “L” is the overcharge protection delay time.
- (2) Set $V1=V2=V3=V4=3.50V$, $V5=4.4V$, make sure the output voltage of DO is “H” level, CO is “L” level. Decrease $V5$ to 3.5V from 4.4V instantaneously, monitor CO voltage and keep a period of time. The time interval when the output voltage of CO turns from “L” to “H” is the overcharge release delay time.

3. Over-discharge Protection Test

Test circuit 2

3.1 Over-discharge threshold (V_{DET2}) and Over-discharge release threshold (V_{REL2})

Set $V1=V2=V3=V4=V5=3.50V$, make sure the output voltages of DO and CO pins are “H” level. Decrease $V5$ gradually, monitor DO voltage and keep the condition not shorter than T_{det2} , the value of $V5$ when the output voltage of DO turns from “H” to “L” is the over-discharge threshold voltage. Increase $V5$, the value of $V5$ when DO returns to “H” level again is the over-discharge release threshold.

3.2 Over-discharge protection delay time and Over-discharge release delay time

- (1) Set $V1=V2=V3=V4=V5=3.50V$, make sure the output voltages of DO and CO pins are “H” level. Decrease $V5$ to 2.0V instantaneously, monitor DO voltage and keep a period of time. The time interval when DO turns from “H” to “L” is the over-discharge protection delay time.
- (2) Set $V1=V2=V3=V4=3.50V$, $V5=2.0V$, make sure CO is “H” level, DO is “L” level. Increase $V5$ to 3.5V instantaneously, monitor DO voltage and keep a period of time. The time interval when the



output voltage of DO turns from “L” to “H” is the overcharge release delay time.

4. Discharge overcurrent and short circuit Protection Test

Test circuit 3

4.1 Discharge overcurrent 1 and 2 threshold (V_{DET3} , V_{DET4}) and short circuit threshold (V_{SHORT})

Set $V1=V2=V3=V4=V5=3.5V$, $V6=0V$, make sure the output voltages of DO and CO pins are “H” level. Increase $V6$ gradually, monitor DO voltage and keep the condition for a period of time, the value of $V6$ when the output voltage of DO turns from “H” to “L”, is the discharge overcurrent 1 threshold (V_{DET3}). Decrease $V6$, the discharge overcurrent 1 protection will be released. V_{DET4} and V_{SHORT} can also be tested by their protection time differences, but $V6$ has a larger change.

4.2 Discharge overcurrent protection delay time and release delay time

- (1) Set $V1=V2=V3=V4=V5=3.50V$, $V6=0V$, make sure the output voltages of DO and CO pins are “H”. Increase $V6$ to 0.2V instantaneously, monitor DO voltage and keep a period of time. The time interval when the output voltage of DO turns from “H” to “L” is the discharge overcurrent 1 protection delay time.
- (2) Set $V1=V2=V3=V4=V5=3.50V$, $V6=0V$, make sure the output voltages of DO and CO pins are “H”. Increase $V6$ instantaneously with its value be larger, monitor DO voltage and keep a period of time. The time interval when the output voltage of DO turns from “H” to “L” is the discharge overcurrent 2 protection delay time, make sure its value is less than the discharge overcurrent 1 protection delay time, then the value of $V6$ at this time is the discharge overcurrent 2 threshold.
- (3) Set $V1=V2=V3=V4=V5=3.50V$, $V6=0V$, make sure the voltages of DO and CO pins are “H”. Increase $V6$ instantaneously with its value lager and larger, monitor DO voltage and keep a period of time. The time interval when DO turns from “H” to “L” is the short circuit protection delay time, make sure its value is less than the discharge overcurrent 2 protection delay time, and the value of $V6$ at this time is the short circuit threshold.
- (4) Set $V1=V2=V3=V4=V5=3.50V$, $V6=0.2V$, make sure the output voltage of DO pin and CO pin is “L” and “H”. Decrease $V6$ to 0V instantaneously, monitor DO voltage and last a period of time. The time interval when DO turns from “L” to “H” is the discharge overcurrent 1 release delay time, we can test the release delay time of discharge overcurrent 2 and short circuit by using the same method.

5. Charge overcurrent Protection Test

Test circuit 4

5.1 Charge overcurrent threshold

Set $V1=V2=V3=V4=V5=3.50V$, $V7=0V$, make sure the output voltages of DO and CO pins are “H”. Increase $V6$ gradually, monitor CO voltage and keep a period of time. The value of $V7$ when the output voltage of CO turns from “H” to “L” is the charge overcurrent threshold.

5.2 Charge overcurrent protection delay time

Set $V1=V2=V3=V4=V5=3.50V$, $V7=0V$, make sure the output voltages of DO and CO pins are “H”. Increase $V7$ to 0.3V instantaneously, monitor the CO voltage and keep a period of time. The time interval when the output voltage of CO pin turns from “H” to “L” is the charge overcurrent protection delay time.



6. Cell Balance threshold Test

Test circuit 5

Set $V_1=V_2=V_3=V_4=V_5=3.50V$, make sure the output voltage of BAL1 pin is 0V. Increase V_1 gradually and monitor the voltage of BAL1. The value of V_1 when the output voltage of BAL1 pin turns from “0” to “H” (the voltage of V_1) is the cell balance threshold. The test method of other cells balance is as same as the method of V_1 .

7. Output/Input Resistance Test

7.1 The output resistances of CO and DO

- (1) The output resistance when the output voltages of CO and DO pins are both “H”.

Test circuit 6

Set $V_1=V_2=V_3=V_4=V_5=3.50V$, $V_6=12.0V$, turn off the switch K and make sure the output voltage of CO pin is “H”. Measure the voltage V_A of CO pin; turn on the switch K, decrease the voltage V_6 gradually from 12V, monitor the value of I_A , and note down the output voltage V_B of CO pin when the value of I_A is 50uA, then the output resistance of CO is calculated as follows: $R_{COH} = (V_A - V_B)/50$ (M Ω)

We can also test the output resistance R_{DOH} of DO pin with using the same method.

- (2) The output resistance when the output voltage of DO pin is “L”.

Test circuit 7

Set $V_1=V_2=V_3=V_4=V_5=2.00V$, $V_8=0.00V$, turn off the switch K and make sure the output voltage of DO pin is “L”. Turn on the switch K, increase the voltage V_8 gradually from 0V, monitor the value of I_A , note down the output voltage V_{DO} of DO pin when the value of I_A is 50uA, then the output resistance of DO is calculated as follows: $R_{DOL} = V_{DO}/50$ (M Ω)

7.2 The output resistances of balance pins BAL1, BAL2, BAL3, BAL4, BAL5

Test circuit 8

- (1) Set $V_{BAL} < V_1 < V_{DET1}$, $V_2=V_3=V_4=V_5=3.5V$, turn on the switch K1 and turn off K2, K3, K4, K5, decrease V_9 from V_{BAL} , note down the value V_9 , which is the value of V_9 when the current is 50uA, then the output resistance when the cell balance turn on is calculated as follows: $R_{BAL1H}=(V_1-V_9)/50$ (M Ω);
- (2) Set $V_1=V_2=V_3=V_4=V_5=3.50V$, turn on the switch K1 and turn off K2, K3, K4, K5, increase V_9 from 0V, note down the value V_9 , which is the value of V_9 when the current is -50uA, then the output resistance when the cell balance turn off is calculated as follows: $R_{BAL1L}=V_9/50$ (M Ω);
- (3) Set $V_{BAL} < V_2 < V_{DET1}$, $V_1=V_3=V_4=V_5=3.5V$, turn on the switch K2 and turn off K1, K3, K4, K5, decrease V_9 from (V_1+V_{BAL}) , note down the value V_9 , which is the value of V_9 when the current is 50uA, then the output resistance when the cell balance turn on is calculated as follows: $R_{BAL2H}=(V_1+V_2-V_9)/50$ (M Ω);
- (4) Set $V_1=V_2=V_3=V_4=V_5=3.50V$, turn on the switch K2 and turn off K1, K3, K4, K5, increase V_9 from V_1 , note down the value V_9 , which is the value of V_9 when the current is -50uA, then the output resistance when the cell balance turn off is calculated as follows: $R_{BAL1L}=(V_9-V_1)/50$ (M Ω);
- (5) Set $V_{BAL} < V_3 < V_{DET1}$, $V_1=V_2=V_4=V_5=3.5V$, turn on the switch K3 and turn off K1, K2, K4, K5, decrease V_9 from $(V_1+V_2+V_{BAL})$, note down the value V_9 , which is the value of V_9 when the current is 50uA, then the output resistance when the cell balance turn on is calculated as follows: $R_{BAL2H}=(V_1+V_2+V_3-V_9)/50$ (M Ω);

BM3451-T20B-T28A

- (6) Set $V_1=V_2=V_3=V_4=V_5=3.50V$, turn on the switch K3 and turn off K1, K2, K4, K5, increase V9 from $(V_1 +V_2)$,note down the value $V_{_9}$, which is the value of V9 when the current is $-50\mu A$, then the output resistance when the cell balance turn off is calculated as follows: $R_{BAL1L}=(V_{_9}-V_1-V_2)/50$ (M Ω);
- (7) Set $V_{BAL} < V_4 < V_{DET1}$, $V_1=V_2=V_4=V_5=3.5V$, turn on the switch K4 and turn off K1, K2, K3, K5,decrease V9 from $(V_1+V_2+V_3+V_{BAL})$,note down the value $V_{_9}$, which is the value of V9 when the current is $50\mu A$, then the output resistance when the cell balance turn on is calculated as follows: $R_{BAL2H}=(V_1+V_2+V_3+V_4-V_{_9})/50$ (M Ω);
- (8) Set $V_1=V_2=V_3=V_4=V_5=3.50V$, turn on the switch K4 and turn off K1, K2, K3, K5, increase V9 from $(V_1 +V_2+V_3)$,note down the value $V_{_9}$, which is the value of V9 when the current is $-50\mu A$, then the output resistance when the cell balance turn off is calculated as follows: $R_{BAL1L}=(V_{_9}-V_1-V_2-V_3)/50$ (M Ω);
- (9) Set $V_{BAL} < V_5 < V_{DET1}$, $V_1=V_2=V_4=V_5=3.5V$, turn on the switch K5 and turn off K1, K2, K3, K4,decrease V9 from $(V_1+V_2+V_3++V_4V_{BAL})$,note down the value $V_{_9}$, which is the value of V9 when the current is $50\mu A$, then the output resistance when the cell balance turn on is calculated as follows: $R_{BAL2H}=(V_1+V_2+V_3+V_4+V_5-V_{_9})/50$ (M Ω);
- (10) Set $V_1=V_2=V_3=V_4=V_5=3.50V$, turn on the switch K5 and turn off K1, K2, K3, K4, increase V9 from $(V_1 +V_2+V_3+V_4)$,note down the value $V_{_9}$, which is the value of V9 when the current is $-50\mu A$, then the output resistance when the cell balance turn off is calculated as follows: $R_{BAL1L}=(V_{_9}-V_1-V_2-V_3-V_4)/50$ (M Ω);

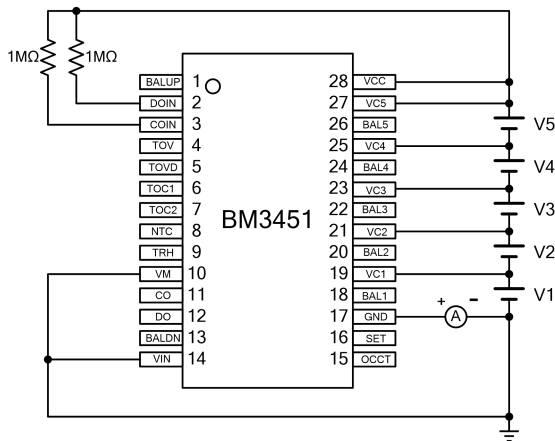

Test Circuit 1

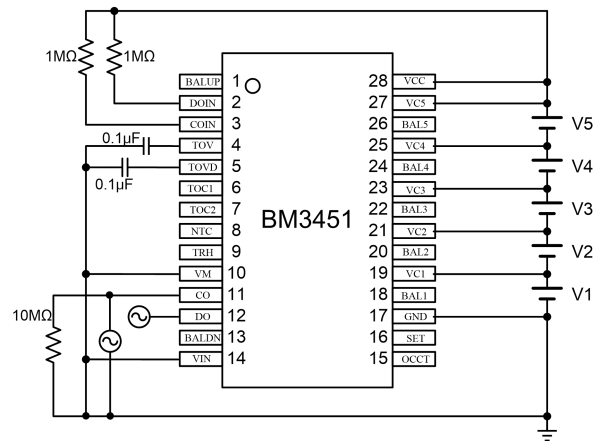

Test Circuit 2



BM3451-T20B-T28A

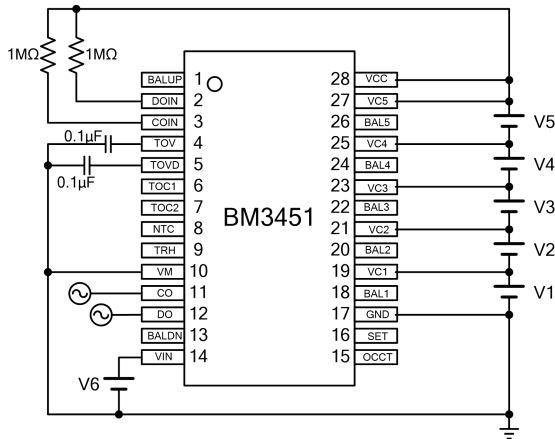

Test Circuit 3

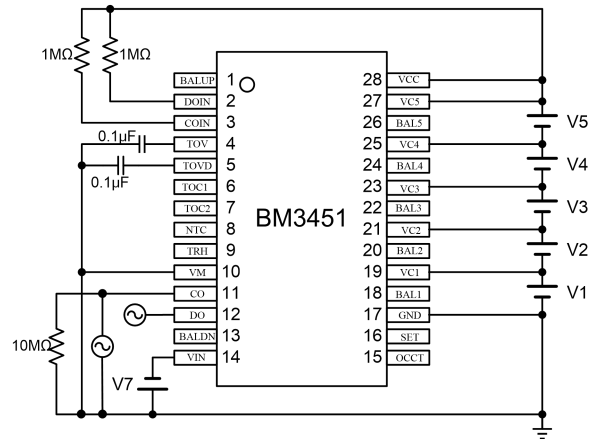

Test Circuit 4

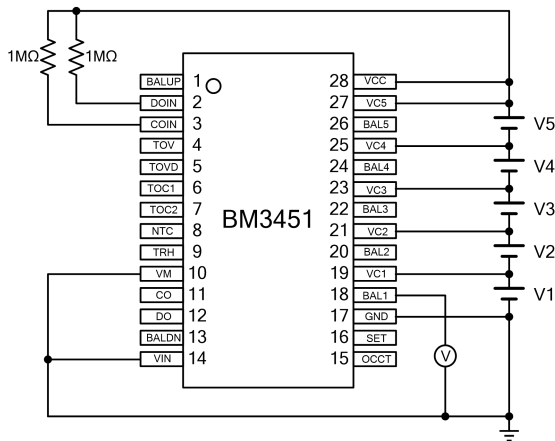

Test Circuit 5

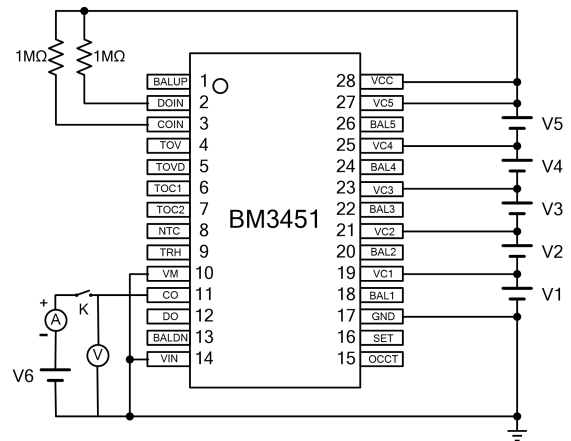

Test Circuit 6

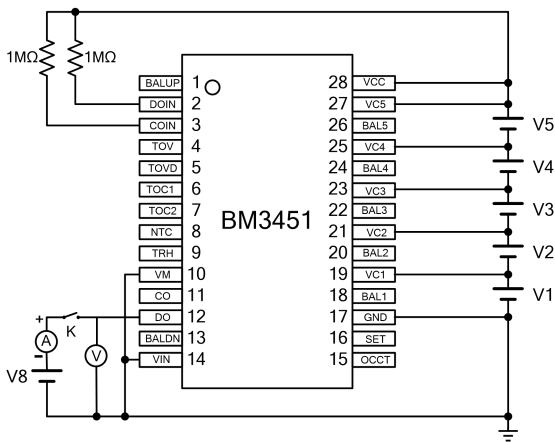

Test Circuit 7

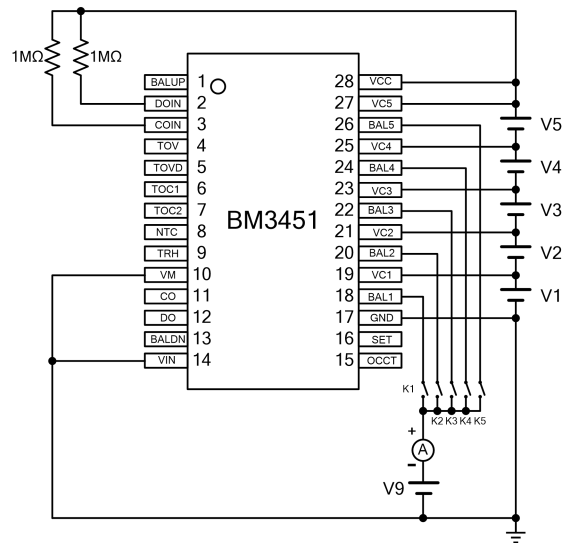

Test Circuit

Package Information

TSSOP20&TSSOP28

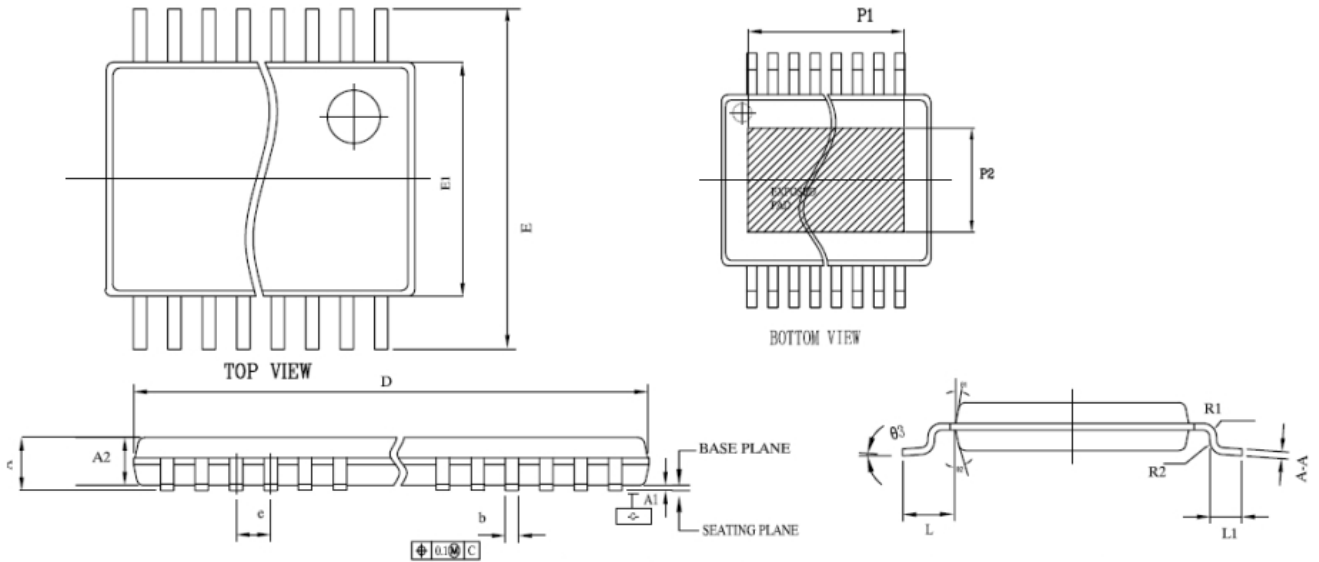

Symbol	符号	TSSOP20		TSSCP28LD	
		Min	Max	Min	Max
A	总高		1.2		1.2
A1	站高	0.05	0.15	0.05	0.15
A2	塑封体高	0.8	1.05	0.8	1.05
E	跨度	6.25	6.55	6.25	6.55
E1	塑封体宽	4.3	4.5	4.3	4.5
D	塑封体长	6.4	6.6	9.6	9.8
L	脚长		1		1
L1		0.45	0.75	0.45	0.75
e	脚间距	0.65		0.65	
b	脚宽	0.19	0.3	0.19	0.3
R1		0.15TYP		0.15TYP	
R2		0.15TYP		0.15TYP	
A-A		0.09	0.2	0.09	0.2
θ 1	脱模斜度	12° TYP		12° TYP	
θ 2	脱模斜度	12° TYP		12° TYP	
θ 3	引脚角度	0	8	0	8

Packing

TSSOP20: MBB packing.13"reel, 4000pcs per reel.

TSSOP28: MBB packing.13"reel, 2000pcs per reel.



RESTRICTIONS ON PRODUCT USE

- The information contained herein is subject to change without notice.
- BYD Semiconductor Company Limited exerts the greatest possible effort to ensure high quality and reliability. Nevertheless, semiconductor devices in general can malfunction or fail due to their inherent electrical sensitivity and vulnerability to physical stress. It is the responsibility of the buyer, when utilizing products, to comply with the standards of safety in making a safe design for the entire system, including redundancy, fire-prevention measures, and malfunction prevention, to prevent any accidents, fires, or community damage that may ensue. In developing your designs, please ensure that products are used within specified operating ranges as set forth in the most recent products specifications.
- The products listed in this document are intended for usage in general electronics applications (computer, personal equipment, office equipment, measuring equipment, industrial robotics, domestic appliances, etc.). These products are neither intended nor warranted for usage in equipment that requires extraordinarily high quality and/or reliability or a malfunction or failure of which may cause loss of human life or bodily injury (“Unintended Usage”). Unintended Usage include atomic energy control instruments, airplane or spaceship instruments, transportation instruments, traffic signal instruments, combustion control instruments, medical instruments, all types of safety devices, etc.. Unintended Usage of products listed in this document shall be made at the customer’s own risk.