

*One-Cell Li Battery Protectors*

**General Description**

The BM192-TCEB-CE is protector for lithium-ion and lithium polymer rechargeable battery with high accuracy voltage detection. It can be used for protecting single cell lithium-ion or/and lithium polymer battery packs from overcharge, overdischarge, overcurrent and short circuit. The IC has suitable protection delay property functions and low power consumption property.

**Applications**

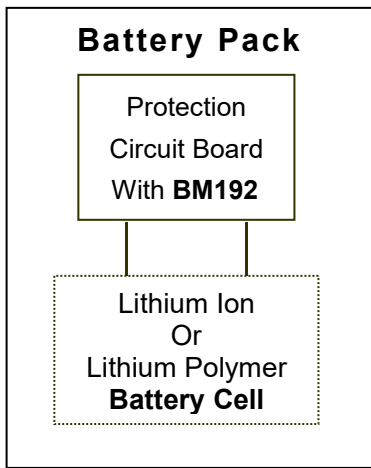

**Features**

- **Overcharge Detection Voltage**
  - 4.375V
  - Accuracy  $\pm 25\text{mV}$  ( $T_a=25^\circ\text{C}$ )
  - $\pm 50\text{mV}$  ( $T_a=-30^\circ\text{C}\sim 80^\circ\text{C}$ )
- **Overdischarge Detection Voltage**
  - 2.500V
  - Accuracy  $\pm 80\text{mV}$  ( $T_a=25^\circ\text{C}$ )
- **Discharge Overcurrent Detection Voltage**
  - 0.150V ( $V_{DD} = 3.300\text{V}$ )
  - Accuracy  $\pm 20\text{mV}$  ( $T_a=25^\circ\text{C}$ )
- **Short Protection Detection Voltage**
  - Typ. 0.800V ( $V_{DD} = 3.300\text{V}$ )
  - Accuracy  $\pm 150\text{mV}$  ( $T_a=25^\circ\text{C}$ )
- **Low Current Consumption**
  - Typ. 4.0uA ( $V_{DD} = 3.900\text{V}$ ,  $T_a=25^\circ\text{C}$ ) (Standard working current)
  - Typ. 1.3uA ( $V_{DD} = 2.000\text{V}$ ,  $T_a=25^\circ\text{C}$ ) (With auto wake up)
- **0V charge function is allowed**
- **Small Package**
  - DFN2.2\*2.9-6L
- **FET general characteristics**
  - $V_{DS}=20\text{V}$
  - $R_{ss(on)} < 40 \text{ m}\Omega$  ( $V_{GS}=3.7\text{V}, I_D=1\text{A}$ )
  - ESD Rating: 2000V HBM

**Typical Application Circuit**

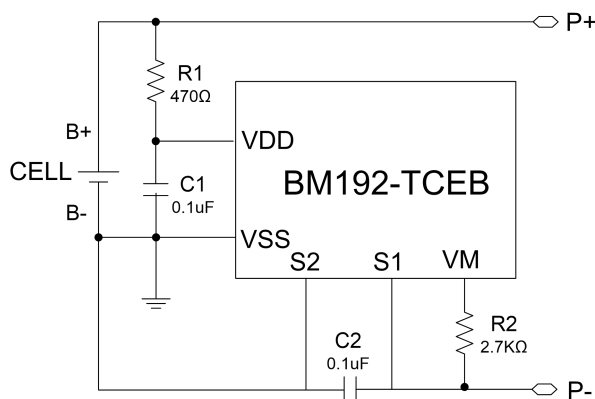

**Notes**

R<sub>1</sub> and C<sub>1</sub> are to stabilize the supply voltage of the BM192-TCEB-CE. R<sub>1</sub> C<sub>1</sub> is hence regarded as the time constant for V<sub>DD</sub> pin. R<sub>1</sub> and R<sub>2</sub> can also be a part of current limit circuit for the BM192-TCEB-CE. Recommended values of these elements are as follows:

- R<sub>1</sub> < 1KΩ. A larger value of R<sub>1</sub> results in higher detection voltage, introducing errors.
- 1.5kΩ < R<sub>2</sub> < 4KΩ. A larger value of R<sub>2</sub> possibly prevents resetting from over-discharge even with a charger.
- R<sub>1</sub>+ R<sub>2</sub> > 1.6KΩ. Smaller values may lead to power consumption over the maximum dissipation rating of the BM192-TCEB-CE.

The requirement or resistors and capacitors and the value of constants should be decided depending upon the system function and characteristics.

### Marking Contents

Symbol	Meaning	Top View
192	Series Name	
TCEB	Product Name	
YW	Lot Number	

### Block Diagram

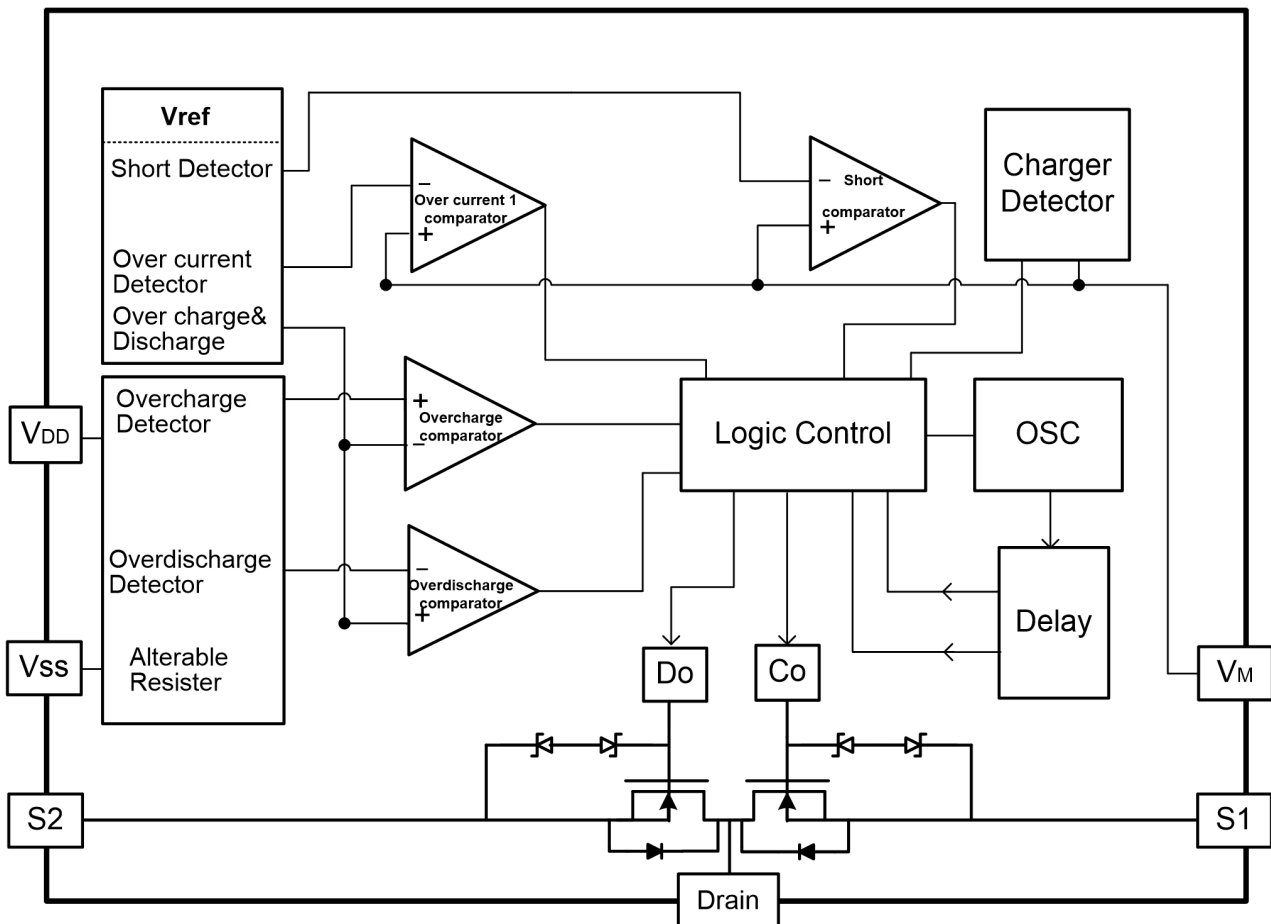

## Pin Description

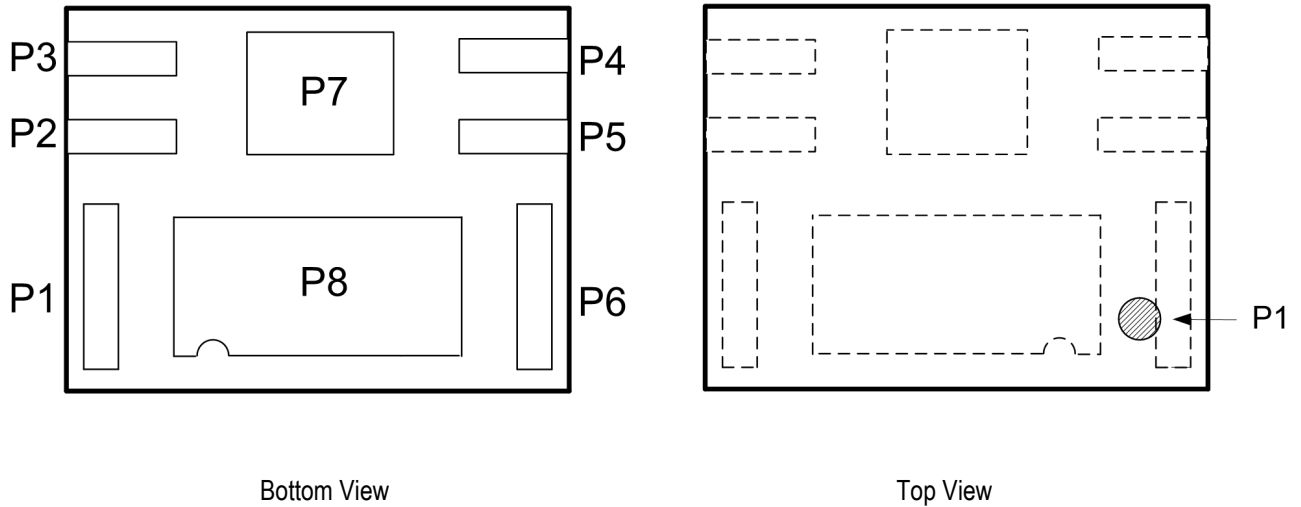

Pin	Symbol	Description
P1	S2	The source terminal of MOSFET switch for discharge control
P2	V <sub>SS</sub>	Ground
P3	V <sub>DD</sub>	Power supply
P4	NC	No Connection
P5	V <sub>M</sub>	Connected to charger's negative pin
P6	S1	The source terminal of MOSFET switch for charge control
P7	IS	The substrate of IC, IS should be floating
P8	MS	The common drain terminal of MOS, MS should be floating

**Electrical Characteristics** <sup>1\*</sup>

(Ta=25°C unless otherwise specified)

Symbol	Item	Conditions	Min.	Typ.	Max.	Unit
<b>DETECTION VOLTAGE AND DELAY TIME</b>						
Vdet1	Overcharge Detection voltage		4.350	<b>4.375</b>	4.400	V
Vrel1	Release Voltage For Overcharge Detection		4.125	<b>4.175</b>	4.225	V
Vdet2	Overdischarge Detection voltage		2.420	<b>2.500</b>	2.580	V
Vrel2	Release Voltage For Overdischarge		2.800	<b>2.900</b>	3.000	V
Vrel2'	Release Voltage For Overdischarge 2	Charger connected	2.420	<b>2.500</b>	2.580	V
Vdet3	Discharge Overcurrent Detection voltage	V <sub>DD</sub> = 3.300V	0.130	<b>0.150</b>	0.170	V
Vshort	Short Protection Voltage	V <sub>DD</sub> = 3.300V	0.650	<b>0.800</b>	0.950	V
Vcha	Charger Detection (Charge Overcurrent)		-0.175	<b>-0.145</b>	-0.115	V
V0cha	0V Battery Charge Starting Charger Voltage	Applied for 0V battery charge function	1.2	-	-	V
Tvdet1	Overcharge detection delay time	V <sub>DD</sub> = 4.0V→4.5V	600	<b>1200</b>	1800	ms
Tvrel1	Overcharge Release Delay Time	V <sub>DD</sub> = 4.5V→4.0V	10	<b>25</b>	40	ms
Treset	Overcharge Reset Delay Time	V <sub>DD</sub> = 4.5V→4.0V→4.5V	8	<b>23</b>	38	ms
Tvdet2	Overdischarge detection delay time	V <sub>DD</sub> = 4.0V→2.0V	36	<b>72</b>	108	ms
Tvrel2	Overdischarge Release Delay Time	V <sub>DD</sub> = 2.0V→3.0V, V <sub>M</sub> = 0V	1.1	<b>2.2</b>	3.3	ms
Tvdet3	Discharge Overcurrent detection delay time	V <sub>DD</sub> = 3.3V, V <sub>M</sub> = 0V→0.2V	5	<b>10</b>	15	ms
Tab	Charge Overcurrent detection delay time	V <sub>DD</sub> = 3.3V, V <sub>M</sub> = 0V→-0.2V	5	<b>10</b>	15	ms
Tshort	Short detection delay time	V <sub>DD</sub> = 3.3V, V <sub>M</sub> = 0V→1.2V	210	<b>420</b>	630	us
Tvrel3	Discharge Overcurrent release delay time	V <sub>DD</sub> = 3.3V, V <sub>M</sub> = 0.2V→0 V	1.1	<b>2.2</b>	3.3	ms
<b>OUTPUT VOLTAGE AND V<sub>M</sub> INTERNAL RESISTANCE</b>						
R <sub>VMD</sub>	Resistance between V <sub>M</sub> and V <sub>DD</sub>	V <sub>DD</sub> =2.0V, V <sub>M</sub> =0V	100	<b>600</b>	900	kΩ
R <sub>VMS</sub>	Resistance between V <sub>M</sub> and V <sub>SS</sub>	V <sub>DD</sub> =3.3V, V <sub>M</sub> =1V	60	<b>100</b>	300	kΩ
<b>OPERATION VOLTAGE AND CURRENT CONSUMPTION</b>						
V <sub>DD</sub>	Operating Input Voltage	V <sub>DD</sub> -V <sub>SS</sub>	1.6	<b>V<sub>DD</sub></b>	8.0	V
V <sub>M</sub>	Operating Input Voltage	V <sub>DD</sub> -V <sub>M</sub>	1.5	-	28	V
I <sub>DD</sub>	Supply Current	V <sub>DD</sub> = 3.9V, V <sub>M</sub> = 0V	-	<b>4.0</b>	6.0	uA
I <sub>STANDBY</sub>	Standby Current	V <sub>DD</sub> = 2.0V, V <sub>M</sub> = 0V→2.0V	-	<b>1.3</b>	2.5	uA

<sup>1\*</sup> The Electrical parameters for this temperature range is guaranteed by design, not tested in production.

**Electrical Characteristics** <sup>1\*</sup>

(Ta=-30°C~80°C unless otherwise specified)

Symbol	Item	Conditions	Min.	Typ.	Max.	Unit
<b>DETECTION VOLTAGE AND DELAY TIME</b>						
Vdet1	Overcharge Detection voltage		4.325	<b>4.375</b>	4.425	V
Vrel1	Release Voltage For Overcharge Detection		4.100	<b>4.175</b>	4.250	V
Vdet2	Overdischarge Detection voltage		2.400	<b>2.500</b>	2.600	V
Vrel2	Release Voltage For Overdischarge		2.800	<b>2.900</b>	3.000	V
Vrel2'	Release Voltage For Overdischarge 2	Charger connected	2.400	<b>2.500</b>	2.600	V
Vdet3	Discharge Overcurrent Detection voltage	V <sub>DD</sub> = 3.300V	0.120	<b>0.150</b>	0.180	V
Vshort	Short Protection Voltage	V <sub>DD</sub> = 3.300V	0.500	<b>0.800</b>	1.100	V
Vcha	Charger Detection (Charge Overcurrent)		-0.185	<b>-0.145</b>	-0.105	V
V0cha	0V Battery Charge Starting Charger Voltage	Applied for 0V battery charge function	1.2	-	-	V
Tvdet1	Overcharge detection delay time	V <sub>DD</sub> = 4.0V→4.5V	480	<b>1200</b>	1920	ms
Tvrel1	Overcharge Release Delay Time	V <sub>DD</sub> = 4.5V→4.0V	8	<b>25</b>	41	ms
Treset	Overcharge Reset Delay Time	V <sub>DD</sub> = 4.5V→4.0V→4.5V	6	<b>23</b>	39	ms
Tvdet2	Overdischarge detection delay time	V <sub>DD</sub> = 4.0V→2.0V	29	<b>72</b>	115	ms
Tvrel2	Overdischarge Release Delay Time	V <sub>DD</sub> = 2.0V→3.0V, V <sub>M</sub> = 0V	0.9	<b>2.2</b>	3.5	ms
Tvdet3	Discharge Overcurrent detection delay time	V <sub>DD</sub> = 3.3V, V <sub>M</sub> = 0V→0.2V	4	<b>10</b>	16	ms
Tab	Charge Overcurrent detection delay time	V <sub>DD</sub> = 3.3V, V <sub>M</sub> = 0V→-0.2V	4	<b>10</b>	16	ms
Tshort	Short detection delay time	V <sub>DD</sub> = 3.3V, V <sub>M</sub> = 0V→1.2V	168	<b>420</b>	672	us
Tvrel3	Discharge Overcurrent release delay time	V <sub>DD</sub> = 3.3V, V <sub>M</sub> = 0.2V→0 V	0.9	<b>2.2</b>	3.5	ms
<b>OUTPUT VOLTAGE AND V<sub>M</sub> INTERNAL RESISTANCE</b>						
R <sub>VMD</sub>	Resistance between V <sub>M</sub> and V <sub>DD</sub>	V <sub>DD</sub> =2.0V, V <sub>M</sub> =0V	75	<b>600</b>	1300	kΩ
R <sub>VMS</sub>	Resistance between V <sub>M</sub> and V <sub>SS</sub>	V <sub>DD</sub> =3.3V, V <sub>M</sub> =1V	40	<b>100</b>	400	kΩ
<b>OPERATION VOLTAGE AND CURRENT CONSUMPTION</b>						
V <sub>DD</sub>	Operating Input Voltage	V <sub>DD</sub> -V <sub>SS</sub>	1.6	<b>V<sub>DD</sub></b>	8.0	V
V <sub>M</sub>	Operating Input Voltage	V <sub>DD</sub> -V <sub>M</sub>	1.5	-	28	V
I <sub>DD</sub>	Supply Current	V <sub>DD</sub> = 3.9V, V <sub>M</sub> = 0V	-	<b>4.0</b>	6.5	uA
I <sub>STANDBY</sub>	Standby Current	V <sub>DD</sub> = 2.0V, V <sub>M</sub> = 0V→2.0V	-	<b>1.3</b>	3.0	uA

<sup>1\*</sup> The Electrical parameters for this temperature range is guaranteed by design, not tested in production.

**Electrical Characteristics** <sup>1\*</sup> (Ta=25°C, GND=0V unless otherwise specified)

Parameter	Symbol	Min.	Typ.	Max.	Unit	Notes
Drain current at cut off of MOS-FET	I <sub>DSS</sub>			1	uA	V <sub>ds</sub> =20V
Source -source on state resistance 1	R <sub>SS(on)1</sub>	21	33	45	mΩ	V <sub>dd</sub> =2.6V , I <sub>D</sub> =1.0A
Source -source on state resistance 2	R <sub>SS (on)2</sub>	20	30	40	mΩ	V <sub>dd</sub> =3.7V , I <sub>D</sub> =1.0A
Source -source on state resistance 3	R <sub>SS (on)3</sub>	19	29	39	mΩ	V <sub>dd</sub> =4.2V , I <sub>D</sub> =1.0A
Body Diode-Forward Voltage	V <sub>SD</sub>	0.4	0.74	1.2	V	I <sub>s</sub> =1.0A , V <sub>GS</sub> =0V

1\* The Electrical parameters for this temperature range is guaranteed by design, not tested in production.

**Electrical Characteristics** <sup>1\*</sup> (Ta=25°C, GND=0V unless otherwise specified)

Item	Symbol	Test condition	Min.	Typ.	Max.	Unit	Note
Discharge	I <sub>det3 1</sub>	VDD=2.6V	3.3	4.5	6.6	A	V <sub>det3</sub> =0.150V
Overcurrent	I <sub>det3 2</sub>	VDD=3.7V	3.6	5.0	7.5	A	
Detect Current	I <sub>det3 3</sub>	VDD=4.2V	3.6	5.2	7.9	A	
Charge	I <sub>cha 1</sub>	VDD=2.6V	2.8	4.4	7.0	A	V <sub>cha</sub> =-0.145V
Overcurrent	I <sub>cha 2</sub>	VDD=3.7V	3.0	4.8	8.0	A	
Detect Current	I <sub>cha 3</sub>	VDD=4.2V	3.1	5.0	8.3	A	

1\* The Electrical parameters for this temperature range is guaranteed by design, not tested in production.

**Absolute Maximum Ratings**(Ta=25°C, V<sub>SS</sub>=0V)

Symbol	Item	Ratings	Unit
V <sub>DD</sub>	Supply Voltage	-0.3 to 8	V
V <sub>M</sub>	V <sub>M</sub> Pin Input Voltage	V <sub>DD</sub> -28 to V <sub>DD</sub> +0.3	V
V <sub>GS</sub>	Gate-Source Voltage	±12	V
V <sub>DS</sub>	Drain- Source Voltage	20	V
I <sub>D</sub>	Drain Current	8	A
P <sub>d</sub>	Power Consumption	150	mW
T <sub>a</sub>	Operating Temperature Range	-30 to 80	°C
T <sub>stg</sub>	Storage Temperature Range	-55 to 125	°C

**Caution: These values must not be exceeded under any conditions!**

## Function Description

### Normal Condition:

$V_{DD}$  is between the Overdischarge Detection Voltage ( $V_{det2}$ ) and Overcharge Detection Voltage ( $V_{det1}$ ) and the  $V_M$  voltage is between Charger Detection Voltage ( $V_{cha}$ ) and the Discharge Overcurrent Detection Voltage ( $V_{det3}$ ), therefore the MOS-FET of charge and discharge are all on. Charging and discharging can be carried out freely.

### Overcharge Condition:

When  $V_{DD}$  increases and passes  $V_{det1}$  during charging under the normal condition, the charge control FET turns off after Overcharge Detection Delay Time ( $T_{vdet1}$ ). If, within  $T_{vdet1}$ ,  $V_{DD}$  becomes lower than  $V_{det1}$  and stays for duration shorter than Overcharge Reset Delay Time ( $T_{reset}$ ) before rising up over  $V_{det1}$  again, this type of instantaneous falling of  $V_{DD}$  is ignored. Otherwise, if the time  $V_{DD}$  stays lower than  $V_{det1}$  is longer than  $T_{reset}$ , the timing related to  $T_{vdet1}$  shall be reset.

### Charge Overcurrent Condition:

If the  $V_M$  voltage falls below the Charger Detection Voltage ( $V_{cha}$ ) during charging under normal condition and it continues for the Charge Overcurrent Delay Time ( $T_{vcha}$ ) or longer, the charge control FET turns off and charging stops. This action is called the charge overcurrent detection.

Charge overcurrent detection works when the discharging control FET is on and the  $V_M$  voltage falls below the Charger Detection Voltage ( $V_{cha}$ ). To an overdischarged battery, only when charging makes the battery voltage higher than the Overdischarge Detection Voltage ( $V_{det2}$ ), the charge overcurrent detection can act. Charge overcurrent state is released, once the voltage difference between  $V_M$  and  $V_{SS}$  becomes less than the Charge Overcurrent Detection Voltage ( $V_{cha}$ ).

### Overcharge Protection Release Condition:

The charging state can be reset and charge control FET will turn on ,as follow condition:

- (1) When the  $V_M$  voltage is between  $V_{det3}$  and  $V_{cha}$ ,  $V_{DD}$  becomes lower than the Overcharge Release Voltage ( $V_{rel1}$ ) , and stays longer than Overcharge Release Delay Time ( $T_{vrel1}$ ), the charge control FET turns on.
- (2) When a charger is disconnected with the battery pack, and the  $V_{DD}$  level is lower than  $V_{det1}$ , the charge control FET turns on.

Note: when a charger keep connecting, even if  $V_{DD}$  level is lower than  $V_{rel1}$ , the overcharge state will not release and charge control FET keep off until disconnect the charger with the battery pack.

### Overdischarge Condition:

While discharging, after  $V_{DD}$  lowers below Overdischarge Detection Voltage ( $V_{det2}$ ), the discharge control FET turns off after Overdischarge Detection Delay Time ( $T_{vdet2}$ ), discharging is stopped.

### Overdischarge Protection Release Condition:

When IC is in overdischarge condition, if a charger is connected to the battery pack, and the battery supply voltage becomes higher than  $V_{det2}$ , the discharge control FET turns on, allowing discharging action.

The discharging state also can be reset and the output of Do becomes high when  $V_{DD}$  becomes higher than the Overdischarge Release Voltage ( $V_{rel2}$ ),  $V_M$  is between  $V_{det3}$  and  $V_{cha}$ , and stays longer than Release Delay Time ( $T_{vrel2}$ ).

When a charger is connected from the battery pack, while the  $V_{DD}$  level is lower than  $V_{det2}$ , the battery pack makes charger current allowable through the internal parasitic diode.

### **Charger Detect Condition:**

When a battery in the overdischarge condition is connected to a charger and provided that the  $V_M$  voltage is lower than the Charger Detection Voltage ( $V_{cha}$ ), IC releases the overdischarge condition and turns on the discharge control FET as the battery voltage becomes higher than the Overdischarge Detection Voltage ( $V_{det2}$ ) since the charger detection function works. This action is called charger detection.

When a battery in the overdischarge condition is connected to a charger and provided that the  $V_M$  pin voltage is between the Charger Detection Voltage ( $V_{cha}$ ) and Discharge Overcurrent Detection Voltage ( $V_{det3}$ ), IC releases the overdischarge condition when the battery voltage reaches the Overdischarge Release Voltage ( $V_{rel2}$ ) or higher.

### **Discharge Overcurrent Protection:**

During discharging, the current varies with load, and  $V_M$  increases with the rise of the discharging current. Once  $V_M$  rises up to the Discharge Overcurrent Detection Voltage ( $V_{det3}$ ) or higher and stays longer than the Discharge Overcurrent Delay Time ( $T_{vdet3}$ ), IC will turn off the discharge control FET. After that Discharge Overcurrent state is removed, i.e.  $V_M < V_{det3}$ , and the circuit recovers to normal condition. The current of Discharge Overcurrent protection is related to  $V_{det3}$  and the ON resistance of the two FETs ( $R_{SS(on)}$ ).

### **Short Circuit Protection:**

This function has the same principle as the overcurrent protection. But, the Short Circuit Protection Delay Time ( $T_{short}$ ) is far shorter than  $T_{vdet3}$  and  $T_{vdet4}$ , and the Short Protection Detection Voltage ( $V_{short}$ ) is far higher than  $V_{det3}$  and  $V_{det4}$ . When the circuit is shorted,  $V_M$  increases rapidly. Once  $V_M \geq V_{short}$ , IC will turn off the discharge control FET. After the short circuit state is removed, i.e.  $V_M < V_{det3}$ , the circuit recovers to the normal condition. The short circuit peak current is related to  $V_{short}$  and the ON resistance of the two FETs ( $R_{SS(on)}$ ).

### **0V battery charge function:**

This function is used to recharge the connected battery whose voltage is 0V due to the self-discharge. When the 0 V battery charge starting charger voltage ( $V_{0cha}$ ) or higher is applied between P+ and P- pins (in the Typical Application Circuits of Page1) by connecting a charger, the charge control FET gate is fixed to  $V_{DD}$  pin voltage. When the voltage between the gate and source of the charge control FET becomes equal to or higher than the turn-on voltage by the charger voltage, the charge control FET turns on to start charging. At this time, the discharge control FET is off and the charging current flows through the internal parasitic diode in the discharge control FET. When the battery voltage becomes equal to or higher than the Overdischarge Detection Voltage ( $V_{det2}$ ), the IC enters the normal condition.



### Operation Timing Chart (1) Overcharge, Timer Reset for Overcharge

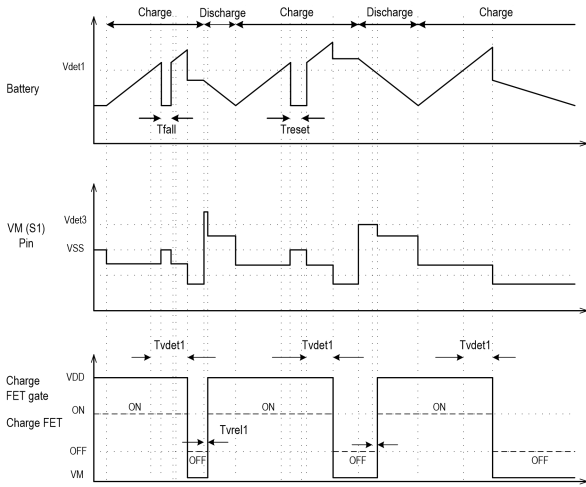

### Operation Timing Chart (3) Discharge Overcurrent and Short Protection

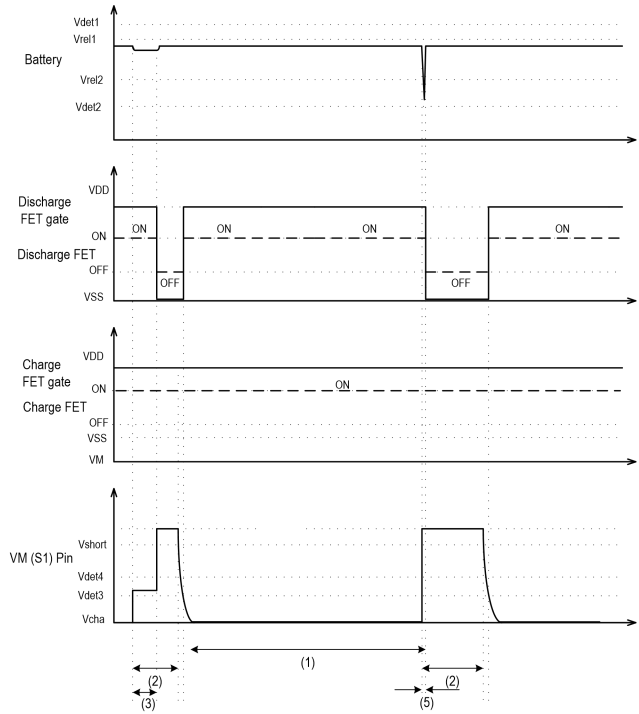

### Operation Timing Chart (2) Overcharge/Overdischarge Detection

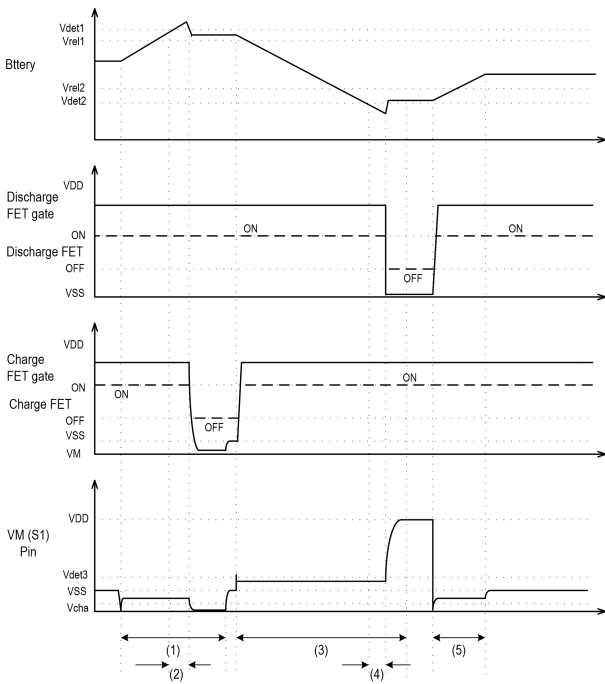

- (1) Normal condition
- (2) Load connection
- (3) Discharge Overcurrent Delay Time (Tvdet3)
- (4) Short Circuit Delay Time (Tshort)

- (1) Charger connected
- (2) Overcharge Detection Delay Time (Tvdet1)
- (3) Load connected
- (4) Overdischarge Detection Delay Time (Tvdet2)
- (5) Normal charging

**Operation Timing Chart (4)  
Charger Connection Detection**

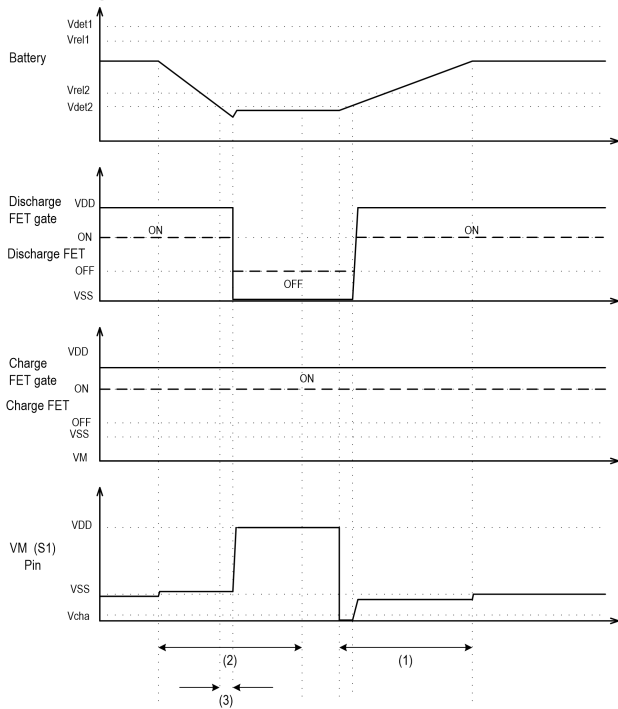

- (1) Charger connection
- (2) Load connection
- (3) Overdischarge Detection Delay ( $T_{vdet2}$ )

**Operation Timing Chart (5)  
Charge Overcurrent Detection**

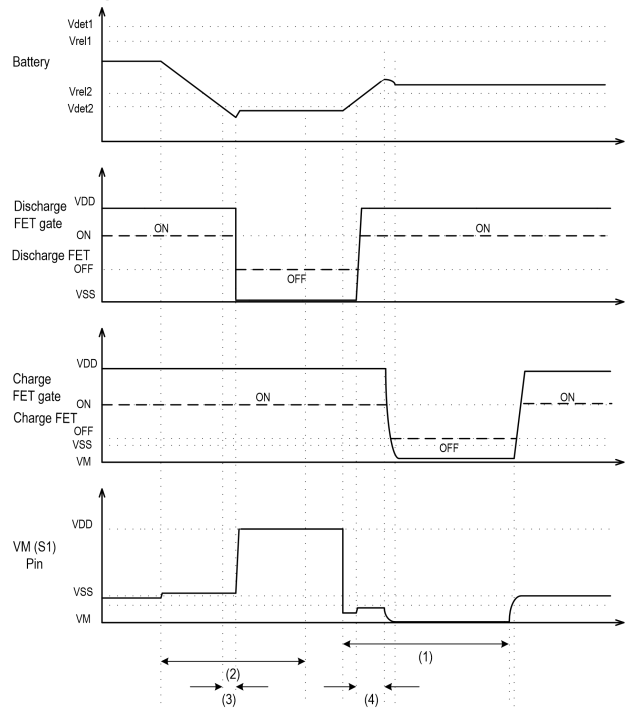

- (1) Charger connection
- (2) Load connection
- (3) Overdischarge Detection Delay Time ( $T_{vdet2}$ )
- (4) Charge Overcurrent Detection Delay Time

## Test Circuits

### (1) Overcharge detection voltage and overcharge release voltage (Test circuit 1)

The Overcharge Detection Voltage ( $V_{det1}$ ) is the voltage between  $V_{DD}$  and  $V_{SS}$  to which when  $V_1$  increases and keeps the condition for overcharge delay time, The charging control FET turns off,  $V_{S1}$  is the threshold of a diode, The Overcharge Release Voltage ( $V_{rel1}$ ) is the voltage between  $V_{DD}$  and  $V_{SS}$  to which when  $V_1$  decreases, The charging control FET turns on,  $V_{S1}=0V$ .

### (2) Overdischarge detection voltage and Overdischarge release voltage (Test circuit 1)

The Overdischarge Detection Voltage ( $V_{det2}$ ) is the voltage between  $V_{DD}$  and  $V_{SS}$  to which when  $V_1$  decreases and keep the condition for overdischarge delay time, The discharging control FET turns off,  $V_{S1}=V_1$ . The overdischarge Release Voltage ( $V_{rel2}$ ) is the voltage between  $V_{DD}$  and  $V_{SS}$  to which when  $V_1$  increases, The discharging control FET turns on,  $V_{S1}=0V$ .

### (3) Discharge overcurrent detection voltage and short circuit detection voltage (Test circuit 2)

The Discharge Overcurrent Detection Voltage ( $V_{det3}$ ) is the voltage between  $V_M$  and  $V_{SS}$  to which when  $V_M$  increases and keep the condition for Discharge Overcurrent Delay Time ( $T_{vdet3}$ ), The discharging control FET turns off,  $V_{S1}=V_1$ .

The Short Circuit Detection Voltage ( $V_{short}$ ) is the voltage between  $V_M$  and  $V_{SS}$  to which when  $V_M$  increases and keep the condition for Short Circuit Delay Time ( $T_{short}$ ), The discharging control FET turns off,  $V_{S1}=V_1$ .

### (4) Charger detection voltage and charge overcurrent detection voltage (Test circuit 2)

In the overdischarge condition, increase  $V_1$  gradually until it is between  $V_{det2}$  and  $V_{rel2}$ . The voltage between  $V_M$  and  $V_{SS}$  to which when  $V_2$  decreases, when the discharging control FET turns on,  $V_{S1}=0V$ , is the Charger Detection Voltage ( $V_{cha}$ ).

In the normal charging condition, the voltage between  $V_M$  and  $V_{SS}$  to which when  $V_2$  decreases, The charging control FET turns off,  $V_{S1}$  is the threshold of a diode, is the charge overcurrent detection voltage. It has the same value as the Charger Detection Voltage ( $V_{cha}$ ).

### (5) 0V battery charge starting charger voltage (Test circuit 2)

Set  $V_1=V_2=0V$  and decrease  $V_2$  gradually. The voltage between  $V_{DD}$  and  $V_M$  when the charging control FET turns on,  $V_{S1}$  is the threshold of a diode, is the 0V battery charge starting charger voltage.

### (6) Normal operation current consumption and power down current consumption (Test circuit 2)

Set  $V_1=3.9V$  and  $V_2=0V$  under normal condition, the current  $I_{DD}$  flowing through  $V_{DD}$  pin is the normal operation consumption current ( $I_{DD}$ ).

Set  $V_1=3.9V$  and  $V_2=0V$ , let IC work in normal condition, set  $V_1$  from 3.9V to 2.0V, then Let the  $V_M$  floating, under overdischarge condition, the current  $I_{DD}$  flowing through  $V_{DD}$  pin is the power down current consumption ( $I_{STANDBY}$ ).

**(7) Overcharge detection (release) delay time and overdischarge detection (release) delay time (Test circuit 3)**

If V1 increases to be  $V_{det1}$  or over  $V_{det1}$  and keeps the condition for some time, the charging control FET will turn off,  $V_{s1}$  is the threshold of a diode, The time is called overcharge detection delay time. It is used to judge whether overcharge happens indeed.

If V1 decreases from  $V_{det1}$  or over  $V_{det1}$  to below  $V_{rel1}$ , the charging control FET will turn on,  $V_{s1}=0V$ . The difference between this time and  $T_{reset}$  is called overcharge release delay time.

If V1 decreases to be  $V_{det2}$  or below  $V_{det2}$  and keeps the condition for some time, the discharging control FET will turn off,  $V_{s1}=V1$ . The time is called overdischarge detection delay time. It is used to judge whether overdischarge happens indeed.

If V1 increases from  $V_{det2}$  or below  $V_{det2}$  to over  $V_{rel2}$  and keeps the condition for some time, the discharging control FET will turn on,  $V_{s1}=0V$ . The time is called overdischarge release delay time.

**(8) Discharge overcurrent detection delay time and short circuit detection delay time (Test circuit 4)**

If V2 increases to be  $V_{det3}$  or over  $V_{det3}$  and keeps the condition for some time, the discharging control FET will turn off,  $V_{s1}=V1$ . The time is called Discharge Overcurrent Delay Time. It is used to judge whether Discharge Overcurrent happens indeed.

If V2 increases to be  $V_{short}$  or over  $V_{short}$  and keeps the condition for some time, the discharging control FET will turn off,  $V_{s1}=V1$ . The time is called short circuit delay time. It is used to judge whether short circuit happens indeed.

**(9) Internal resistance  $V_M$  -VDD and  $V_M$  -VSS (Test circuit 4)**

Set  $V1=2.0V$ ,  $V2=0V$ ,  $V1/I_{VM}$  is the internal resistance  $R_{VMD}$ .

Set  $V1=3.3V$ ,  $V2=1V$ ,  $V2/I_{VM}$  is the internal resistance  $R_{VMS}$ .

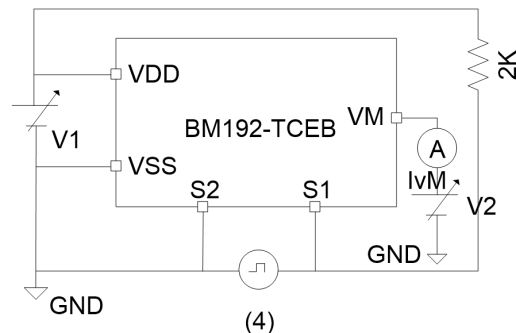
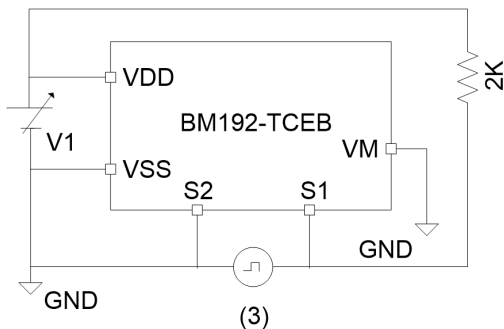
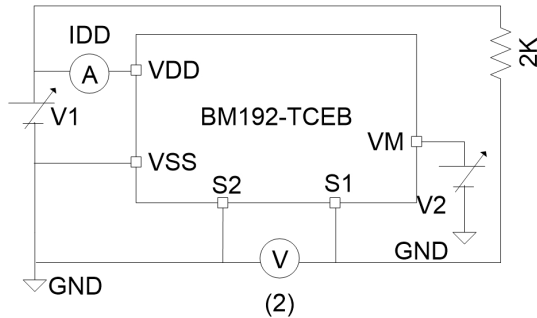
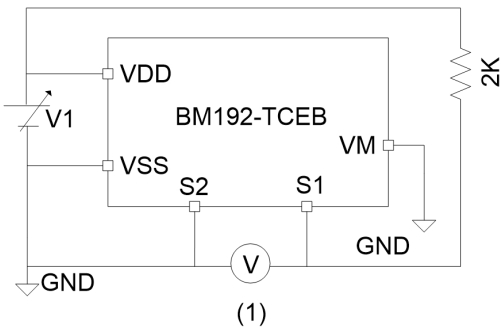

## Package Outline

### DFN2.2\*2.9-6L

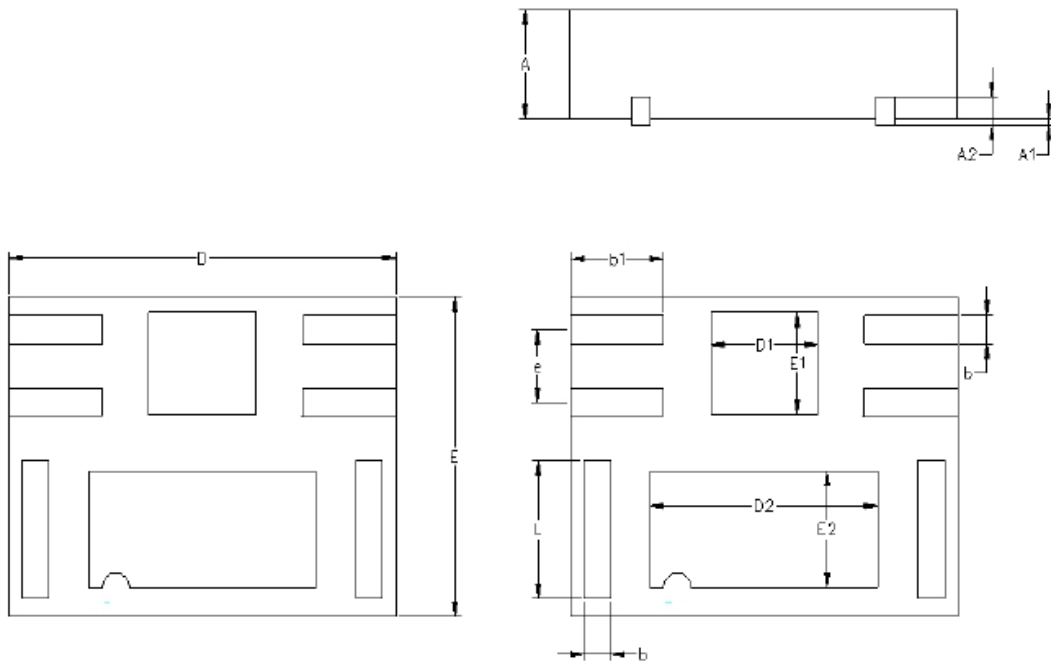

## Dimensions (mm)

COMMON DIMENSIONS (mm)			
RER	MIN	NOM	MAX
A	0.70	0.75	0.80
A1	0		0.05
A2	0.20REF		
D	2.85	2.90	2.95
E	2.15	2.20	2.25
D1	0.75	0.80	0.85
E1	0.65	0.70	0.75
b	0.15	0.20	0.25
e	0.5BSC		
L	0.90	0.95	1.00
b1	0.65	0.70	0.75
D2	1.65	1.70	1.75
E2	0.75	0.80	0.85

## Packing

MBB packing.7"reel: 3000pcs per reel.

### PCB Layout

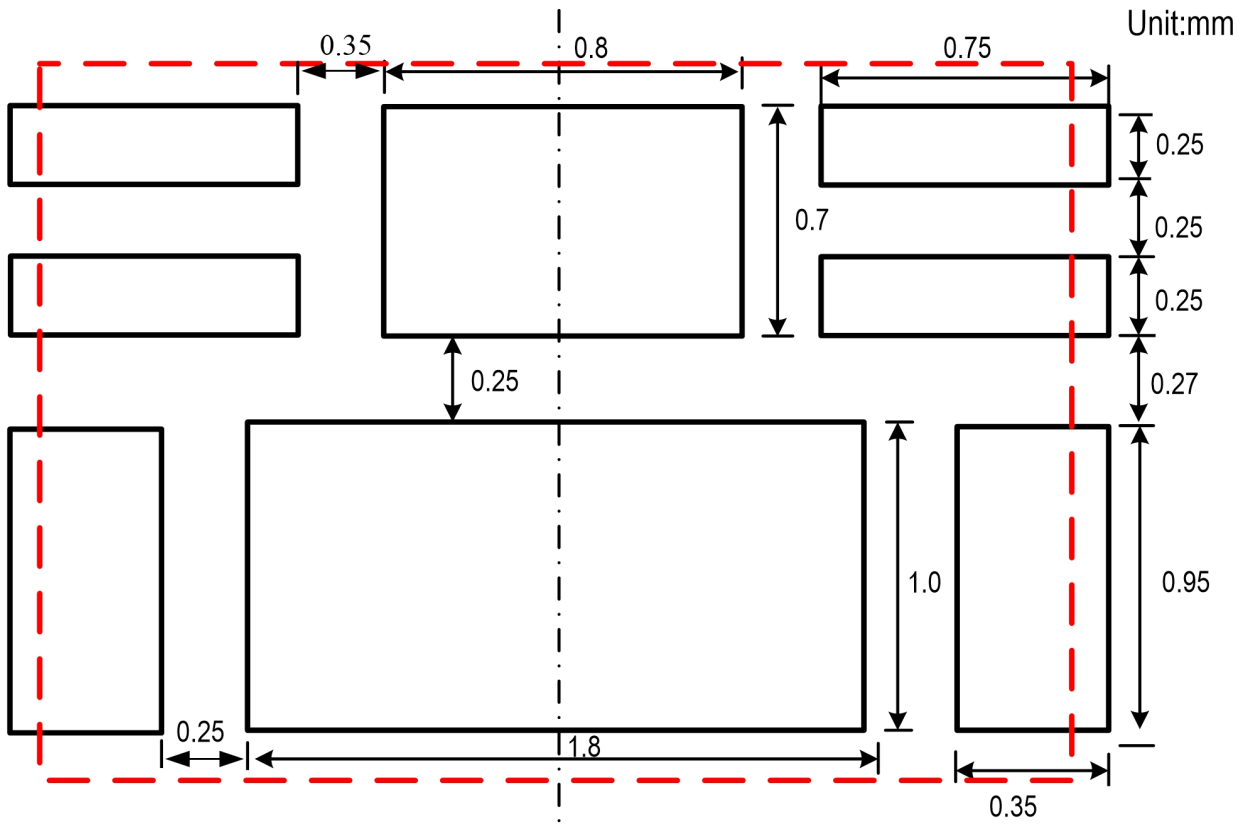



## RESTRICTIONS ON PRODUCT USE

- The information contained herein is subject to change without notice.
- BYD Semiconductor Company Limited exerts the greatest possible effort to ensure high quality and reliability. Nevertheless, semiconductor devices in general can malfunction or fail due to their inherent electrical sensitivity and vulnerability to physical stress. It is the responsibility of the buyer, when utilizing products, to comply with the standards of safety in making a safe design for the entire system, including redundancy, fire-prevention measures, and malfunction prevention, to prevent any accidents, fires, or community damage that may ensue. In developing your designs, please ensure that products are used within specified operating ranges as set forth in the most recent products specifications.
- The products listed in this document are intended for usage in general electronics applications (computer, personal equipment, office equipment, measuring equipment, industrial robotics, domestic appliances, etc.). These products are neither intended nor warranted for usage in equipment that requires extraordinarily high quality and/or reliability or a malfunction or failure of which may cause loss of human life or bodily injury (“Unintended Usage”). Unintended Usage include atomic energy control instruments, airplane or spaceship instruments, transportation instruments, traffic signal instruments, combustion control instruments, medical instruments, all types of safety devices, etc.. Unintended Usage of products listed in this document shall be made at the customer’s own risk.