

## 6 Cells Battery Professional Protectors

### General Description / 产品概述

The BM3560 is a professional protection IC for 6 cells rechargeable battery pack; it is highly integrated, high accuracy and generally used in high-and-mid end power tools, electric bicycle and UPS applications. The BM3560 works constantly to monitor each cell's voltage, the current of charge or discharge, wire breaking or not and the temperature of the environment to provide overcharge, over-discharge, discharge overcurrent, short circuit, charge overcurrent, breaking wire and temperature protections, etc. Besides, it also can change the protection delay time of over-discharge and discharge overcurrent by setting the external capacitors.

BM3560 系列是一款 6 节专用的可充电电池保护芯片，具有高精度、高集成度的特点，适用于中高端电动工具，电动自行车以及 UPS 后备电源等应用领域。芯片通过检测各节电池的电压、充放电电流、环境温度以及采样线通断等信息实现电池过充、过放、放电过电流、短路、充电过电流、高低温以及断线等保护功能，同时可通过外置电容灵活调节过放、放电过流 1、放电过流 2 的保护延时。

### Features / 功能特点

(1) High-accuracy voltage detection for each cell

各节电池的高精度电压检测功能：

- |                             |                 |                                   |
|-----------------------------|-----------------|-----------------------------------|
| • Overcharge threshold      | 3.6 V ~ 4.6 V   | accuracy: ±25 mV (+25°C)          |
| 过充电检测电压                     |                 | 精度±25 mV (+25°C)                  |
|                             |                 | accuracy: ±40 mV (-40°C to +85°C) |
|                             |                 | 精度±40 mV (-40°C至+85°C)            |
| • Overcharge hysteresis     | 0.12 / 0.20 V   | accuracy: ±50 mV                  |
| 过充电迟滞电压                     |                 | 精度±50 mV                          |
| • Over-discharge threshold  | 1.6 V ~ 3.0 V   | accuracy: ±80 mV                  |
| 过放电检测电压                     |                 | 精度±80 mV                          |
| • Over-discharge hysteresis | 0 / 0.2 / 0.4 V | accuracy: ±100 mV                 |
| 过放电迟滞电压                     |                 | 精度±100 mV                         |

(2) Three grades voltage detection of discharge overcurrent

3 段放电过电流检测功能：

- |                           |                                |                  |
|---------------------------|--------------------------------|------------------|
| • Discharge overcurrent 1 | 0.050 V ~ 0.150 V (25 mV step) | accuracy: ±15 mV |
| 过电流检测电压 1                 |                                | 精度±15 mV         |
| • Discharge overcurrent 2 | 0.1 / 0.2 / 0.3 / 0.4 V        |                  |
| 过电流检测电压 2                 |                                |                  |
| • Short circuit           | 0.4 / 0.5 / 0.6 / 0.8 V        |                  |
| 短路检测电压                    |                                |                  |

(3) Charge overcurrent detection

充电过电流检测功能

Detection voltage -0.030 V ~ -0.150 V (10 mV step)

充电过电流检测电压



Block Diagram /功能框图

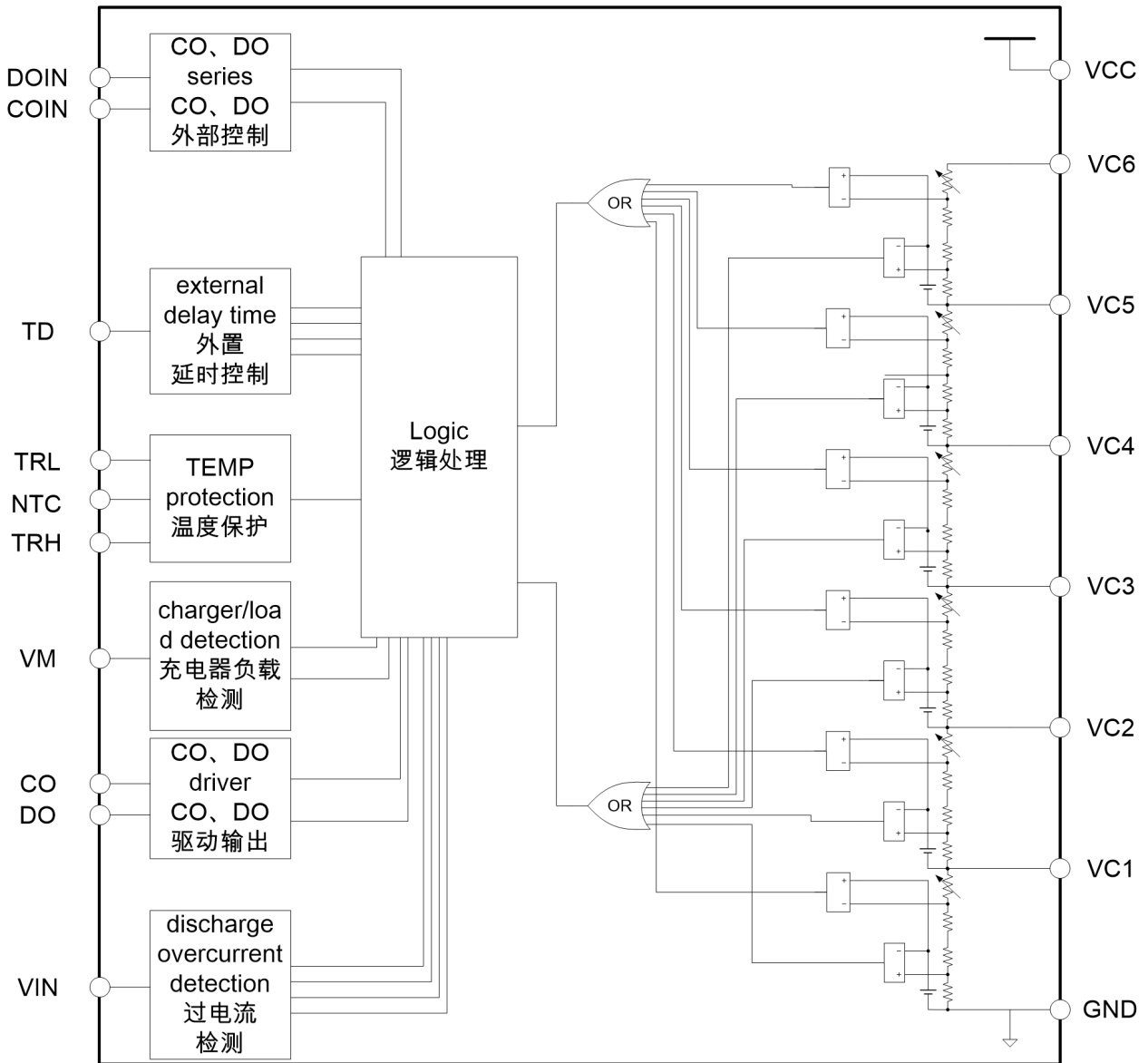

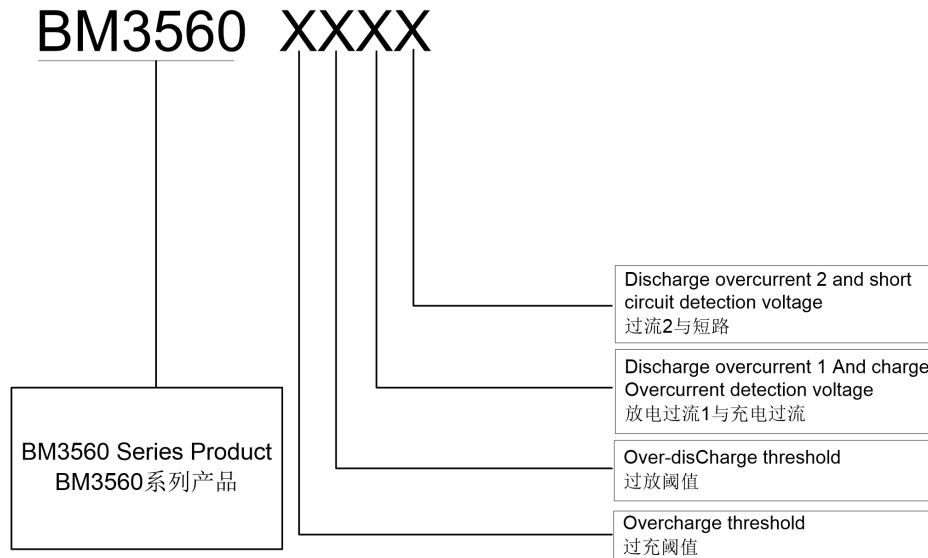
**Selection Guides /产品选型**
**1. Products name structure /产品命名**

**2. 产品目录**
**Products catalogue**

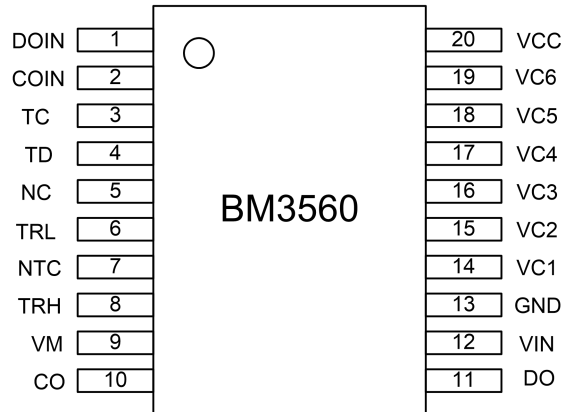
Type/Item 型号/项目	Overcharge protection voltage $V_{DET1}$ 过充 阈值	Overcharge release voltage $V_{REL1}$ 过充恢复 阈值	Over- discharge protection voltage $V_{DET2}$ 过放 阈值	Over- discharge release voltage $V_{REL2}$ 过放恢复 阈值	Discharge overcurrent 1 detection voltage $V_{OC1}$ 过流 1 阈值	Discharge overcurrent 2 detection voltage $V_{OC2}$ 过流 2 阈值	Short circuit detection voltage $V_{SHORT}$ 短路 阈值	Charge overcurrent detection voltage $V_{OVCC}$ 充电过流 阈值
BM3560-QMDB	4.175V	4.060V	2.750V	3.000V	0.100V	0.200V	0.500V	-0.060V
BM3560-RJAI	4.200V	4.080V	2.500V	2.800V	0.050V	0.100V	0.400V	-0.060V
BM3560-SMDD	4.225V	4.105V	2.750V	3.000V	0.100V	0.300V	0.600V	-0.060V
BM3560-TNDB	4.250V	4.130V	2.800V	3.000V	0.100V	0.200V	0.500V	-0.060V
BM3560-BFGB	3.650V	3.450V	2.130V	2.410V	0.100V	0.200V	0.500V	-0.100V

**Pin Configurations / 引脚排布**

Top View

Pin number 引脚号	Name 名称	Description 描述
1	DOIN	DO controller for extended application DO 控制端子
2	COIN	CO controller for extended application CO 控制端子
3	TC	Adjust terminal for discharge overcurrent 1 delay time by connecting to TD 过流 1 延时独立调节端子，可通过连接 TD 调节过流 1 延时大小
4	TD	Connect to a capacitor for setting the delay time of over-discharge protection、 discharge overcurrent 1 protection、discharge overcurrent 2 protection 接电容，用于控制过放电、过电流 1、过电流 2 检测延时
5	NC	No connect 无连接
6	TRL	Under -temperature protection reference 接电阻，用于调节低温保护温度
7	NTC	Cell temperature detection 接负温度系数热敏电阻，用于温度检测
8	TRH	Over-temperature protection reference 接电阻，用于调节高温保护温度
9	VM	Voltage detection terminal 1 for detecting load or charger 过放和过电流保护锁定、充电器及负载检测端子
10	CO	Charge power MOSFET control terminal, high level and Hi-Z output 充电控制 MOS 栅极连接端子，高电平与高阻态输出
11	DO	Discharge power MOSFET control terminal, CMOS output 放电控制 MOS 栅极连接端子，CMOS 输出
12	VIN	Charge and Discharge overcurrent Voltage detection terminal 放电过电流及充电过电流检测端子

13	GND	Ground pin of the IC, Cell1 negative input 芯片的地、电池 1 的负电压连接端子
14	VC1	Cell1 positive input, Cell2 negative input 电池 1 的正电压、电池 2 的负电压连接端子
15	VC2	Cell2 positive input, Cell3 negative input 电池 2 的正电压、电池 3 的负电压连接端子
16	VC3	Cell3 positive input, Cell4 negative input 电池 3 的正电压、电池 4 的负电压连接端子
17	VC4	Cell4 positive input, Cell5 negative input 电池 4 的正电压、电池 5 的负电压连接端子
18	VC5	Cell5 positive input, Cell6 negative input 电池 5 的正电压、电池 6 的负电压连接端子
19	VC6	Cell6 positive input 电池 6 的正电压连接端子
20	VCC	Power supply, Cell6 positive input 芯片的电源、电池 6 的正电压连接端子

### Absolute Maximum Ratings /绝对最大额定值

Item 项目	Symbol 符号	Description 适用端子	Ratings 绝对最大额定值	Unit 单位
Power supply voltage 电源电压	VCC	-	GND-0.3 ~ GND+40	V
Single cell input voltage 各节电池电压	V <sub>n</sub>	VC6、VC5、VC4、 VC3、VC2、VC1	GND-0.3 ~ GND+6	V
Low voltage pin input 低压管脚耐压	V <sub>in-lv</sub>	TC、TD、TRL、 NTC、TRH、VIN	GND-0.3 ~ GND+5.5	V
VM input voltage VM 输入端子电压	VM	VM	VCC-30 ~ GND+30	V
DO output voltage DO 输出端子电压	V <sub>DO</sub>	DO	VCC-30 ~ VCC+0.3	V
CO output voltage CO 输出端子电压	V <sub>CO</sub>	CO	VCC-30 ~ VCC+0.3	V
Operating temperature 工作环境温度	T <sub>A</sub>	-	-40 ~ +85	°C
Storage temperature 贮存温度	T <sub>STG</sub>	-	-40 ~ +125	°C
ESD Rating 静电防护等级	V <sub>ESD</sub>	HBM	2000	V

**Caution:** The absolute maximum ratings are rated values exceeding which the product could suffer physical damage. These values must therefore not be exceeded in any conditions.

注意：绝对最大额定值是指无论在任何条件下都不能超过的额定值。一旦超过此额定值，有可能造成产品劣化等物理性损伤。

**Electrical Characteristics / 电气特性**

 (T<sub>A</sub>=25°C unless otherwise specified) (除特殊说明外: T<sub>A</sub>=25°C)

Item 项 目	Symbol 符号	Test conditions*1 测试条件*1	Min. 最小值	Typ. 典型值	Max. 最大值	Unit 单位	*2	
Power supply voltage 电源电压	VCC	-	5	-	30	V	1	
Operating consumption (with NTC resistor) 正常功耗 (带 NTC 电阻)	I <sub>VCC</sub>	V1=V2=V3=V4=V5=V6=3.5V	-	20	35	μA		
Operating consumption (without NTC resistor) 正常功耗 (无 NTC 电阻)	I <sub>VCC</sub>	V1=V2=V3=V4=V5=V6=3.5V	-	10	20	μA		
VC6 consumption VC5 功耗	I <sub>VC6</sub>	V1=V2=V3=V4=V5=V6=3.5V	-	3	6	μA		
Sleeping consumption 休眠功耗	I <sub>STB</sub>	V1=V2=V3=V4=V5=V6=2.0V	-	5	10	μA		
Overcharge 过充电	Protection threshold 保护阈值	V <sub>DET1</sub>	V1=V2=V3=V4=V5=3.5V V6=3.5V→4.4V	V <sub>DET1</sub> -0.025	V <sub>DET1</sub>	V <sub>DET1</sub> +0.02 5	V	2
	Protection delay time 保护延时	T <sub>OV</sub>	V1=V2=V3=V4=V5=3.5V V6=3.5V→4.4V	0.5	1.0	1.5	s	
	Release threshold 解除阈值	V <sub>REL1</sub>	V1=V2=V3=V4=V5=3.5V V6=4.4V→3.5V	V <sub>REL1</sub> -0.05	V <sub>REL1</sub>	V <sub>REL1</sub> +0.05	V	
	Release delay time 解除延时	T <sub>REL1</sub>	V1=V2=V3=V4=V6=3.5V V6=4.4V→3.5V	4	8	12	ms	
	Temperature factor(1) 温度系数 1	K <sub>U1</sub>	T <sub>a</sub> = -40°C to 85°C	-0.6	0	0.6	mV/°C	
	Reset time 重置延时	T <sub>RESET</sub>	-	4	8	12	ms	
Over- Discharge 过放电	Protection threshold 保护阈值	V <sub>DET2</sub>	V1=V2=V3=V4=V5=3.5V V6=3.5V→2.0V	V <sub>DET2</sub> -0.08	V <sub>DET2</sub>	V <sub>DET2</sub> +0.08	V	
	Protection delay time 保护延时	T <sub>OVD</sub>	V1=V2=V3=V4=V5=3.5V C <sub>TD</sub> =0.1μF V6=3.5V→2.0V	0.5	1.0	1.5	s	
	Release threshold 解除阈值	V <sub>REL2</sub>	V1=V2=V3=V4=V5=3.5V V6=2.0V→3.5V	V <sub>REL2</sub> -0.10	V <sub>REL2</sub>	V <sub>REL2</sub> +0.10	V	

	Release delay time 解除延时	$T_{REL2}$	$V1=V2=V3=V4=V5=3.5V$ $V6=2.0V \rightarrow 3.5V$	4	8	12	ms	
	Reset time 重置延时	$T_{RESET}$	-	4	8	12	ms	
Discharge overcurrent 1 放电过流 1	Protection threshold 保护阈值	$V_{OC1}$	$V1=V2=V3=V4=V5=V6=3.5V$ $V7=0V \rightarrow 0.12V$	$V_{OC1}$ *85%	$V_{OC1}$	$V_{OC1}$ *115%	V	
	Protection delay time 保护延时	$T_{OC1}$	$V1=V2=V3=V4=V5=V6=3.5V$ TC 悬空, $C_{TD}=0.1\mu F$ $V7=0V \rightarrow 0.12V$	500	1000	1500	ms	
	Protection delay time 保护延时*	$T_{OC1^*}$	$V1=V2=V3=V4=V5=V6=3.5V$ TC 连接 TD, $C_{TD}=0.1\mu F$ $V7=0V \rightarrow 0.12V$	125	250	375	ms	
	Release delay time 解除延时	$T_{ROC1}$	$V1=V2=V3=V4=V5=V6=3.5V$ $V7=0V \rightarrow 0.12V \rightarrow 0V$ $V11=10V \rightarrow 0V$	20	50	80	ms	
	Resistance between VM and GND 过流下拉电阻	$R_{VMS}$	$V1=V2=V3=V4=V5=V6=3.5V$ $V7=0V \rightarrow 0.12V$	100	300	500	k $\Omega$	
	Temperature factor(2) 温度系数 2	$K_{U2}$	$T_a = -40^{\circ}C$ to $85^{\circ}C$	-0.1	0	0.1	mV/ $^{\circ}C$	
Discharge overcurrent 2 放电过流 2	Protection threshold 保护阈值	$V_{OC2}$	$V1=V2=V3=V4=V5=V6=3.5V$ $V7=0V \rightarrow 0.5V$	$V_{OC2}$ *80%	$V_{OC2}$	$V_{OC2}$ *120%	V	
	Protection delay time 保护延时	$T_{OC2}$	$V1=V2=V3=V4=V5=V6=3.5V$ TC 悬空, $C_{TD}=0.1\mu F$ $V7=0V \rightarrow 0.5V$	50	100	150	ms	
	Protection delay time 保护延时	$T_{OC2}$	$V1=V2=V3=V4=V5=V6=3.5V$ TC 连接 TD, $C_{TD}=0.1\mu F$ $V7=0V \rightarrow 0.5V$	40	80	120	ms	
	Release delay time 解除延时	$T_{ROC2}$	$V1=V2=V3=V4=V5=V6=3.5V$ $V7=0V \rightarrow 0.5V \rightarrow 0V$ $V11=10V \rightarrow 0V$	20	50	80	ms	
Short circuit 短路	Protection threshold 保护阈值	$V_{SHORT}$	$V1=V2=V3=V4=V5=V6=3.5V$ $V7=0V \rightarrow 1.2V$	$V_{SHORT}$ *80%	$V_{SHORT}$	$V_{SHORT}$ *120%	V	
	Protection delay time 保护延时	$T_{SHORT}$	$V1=V2=V3=V4=V5=V6=3.5V$ $V7=0V \rightarrow 1.2V \rightarrow 0V$	100	300	600	$\mu s$	

3



Charge overcurrent 充电过流	Protection threshold 保护阈值	$V_{OVCC}$	$V1=V2=V3=V4=V5=V6=3.5V$ $V8=0V \rightarrow -0.2V$	$V_{OVCC}$ -0.020	$V_{OVCC}$	$V_{OVCC}$ +0.02 0	V	4
	Protection delay time 保护延时	$T_{OVCC}$	$V1=V2=V3=V4=V5=V6=3.5V$ $V8=0V \rightarrow -0.2V$	5	10	15	ms	
TEMP protection 温度保护	Charge over-temperature 充电高温	$T_{CH}$	$V1=V2=V3=V4=V5=V6=3.5V$	-4	$T_{CH}$	+4	°C	/
	Charge over-temperature hysteresis 充电高温迟滞	$T_{CHR}$	$V1=V2=V3=V4=V5=V6=3.5V$	/	5	/	°C	
	Discharge over-temperature 放电高温	$T_{DH}$	$V1=V2=V3=V4=V5=V6=3.5V$	-4	$T_{DH}$	+4	°C	
	Discharge over-temperature hysteresis 放电高温迟滞	$T_{DHR}$	$V1=V2=V3=V4=V5=V6=3.5V$	/	10	/	°C	
	Charge under-temperature 充电低温	$T_{CL}$	$V1=V2=V3=V4=V5=V6=3.5V$	-5	$T_{CL}$	+5	°C	
	Charge under-temperature hysteresis 充电低温迟滞	$T_{CLR}$	$V1=V2=V3=V4=V5=V6=3.5V$	/	5	/	°C	
Output resistances 输出电阻	CO	$R_{CO}$	Normal state, Co "H" (12V) 正常态, Co 为"H" (12V)	3	5	8	kΩ	5
	DO	$R_{DO}$	Normal state, Do "H" (12V) 正常态, Do 为"H" (12V)	3	5	8	kΩ	6
Protecting state, Do "L" 保护态, Do 为"L"			0.20	0.35	0.50			

\*1: All the test condition parameters above are designed based on Li+ parameters, other grade parameters can adjust by their own actual voltages. The protection delay time above does not include capacitance error, it is recommend to select a higher accuracy capacitance within  $\pm 5\%$ .

以上测试条件均以锂电参数参考设计，其他档位参数根据实际电压调整。上述保护延时不包括电容器精度误差， $C_{TD}$  电容建议选择精度 $\pm 5\%$ 规格。

\*2: The test circuit symbols.

测试电路图的记号。

## Function Description /工作说明

### 1. Overcharge /过充电

During charging,  $V_{IN} > V_{OVCC}$  when IC doesn't work in the state of charge overcurrent, If any of V1, V2, V3, V4, V5 and V6 is higher than  $V_{DET1}$  and lasts longer than  $T_{OV}$ , BM3560 chip considers that the batteries work in the state of overcharge, the output voltage of CO will become high resistance from high level, and then it will be pulled down to low level by external resistor. The charge MOSFET will be turned off and stop charging.

电池充电且  $V_{IN} > V_{OVCC}$  即未发生充电过流时，只要 V1、V2、V3、V4、V5 或 V6 中任意一节电池电压高过  $V_{DET1}$  并持续时间达到或超过  $T_{OV}$ ，芯片即认为电池包中出现了过充电状态，CO 由高电平变为高阻态，被外接电阻下拉至低电平，将充电控制 MOS 管关断，停止充电。

The overcharge protection state will be released if any of the next conditions occurs:

- (1) All cells' voltage is less than the overcharge release threshold  $V_{REL1}$  and stays a period of time  $T_{REL1}$ ;
- (2)  $V_M > 200mV$  (connecting to the load), battery voltage is lower than  $V_{DET1}$  and stays a period of time  $T_{REL1}$ .

满足下面两个条件之一即可解除过充电状态:

- (1) 所有电芯的电压都低于  $V_{REL1}$  并持续  $T_{REL1}$ ;
- (2)  $V_M > 200mV$  (接入负载)，电池电压低于  $V_{DET1}$  并持续  $T_{REL1}$ 。

### 2. Over-discharge /过放电

During discharging,  $V_{IN} < V_{OC1}$  when IC doesn't work in the state of discharge overcurrent. If any of V1, V2, V3, V4, V5 and V6 is less than  $V_{DET2}$  and lasts longer than  $T_{OVD}$ . BM3560 chip considers that the batteries work in the state of over-discharge and the output voltage of DO will turn to GND. The discharge MOSFET will be turned off and stop discharging, then the chip will enter sleeping mode.

电池放电且  $V_{IN} < V_{OC1}$  即未发生放电过流时，只要 V1、V2、V3、V4、V5 或 V6 中任意一节电池电压低于  $V_{DET2}$  并持续时间达到或超过  $T_{OVD}$ ，芯片即认为电池包中出现了过放电状态，DO 由高电平变为低电平，将放电控制 MOS 管关断，停止放电，同时芯片进入休眠模式。

The over-discharge protection state will be released if any of the next conditions occurs:

- (1)  $V_M < 3V$ , all cells' voltage is higher than  $V_{REL2}$  and stays a period of time  $T_{REL2}$ .
- (2)  $V_M < -200mV$  (connecting to the charger), all cells' voltage is higher than  $V_{DET2}$  and stays a period of time  $T_{REL2}$ .

满足下面两个条件之一即可解除过放电状态（休眠状态）:

- (1)  $V_M < 3V$  且所有电芯的电压都高于  $V_{REL2}$  并持续  $T_{REL2}$ ;
- (2)  $V_M < -200mV$  (接入充电器)，电池电压高于  $V_{DET2}$  并持续  $T_{REL2}$ 。

### 3. Discharge overcurrent /放电过电流

During discharging, the current varies with the load. The voltage of  $V_{IN}$  becomes higher with the current increasing. When the voltage of  $V_{IN}$  is higher than  $V_{OC1}$  and stays longer than  $T_{OC1}$ , we think the IC works in the state of discharge overcurrent 1; When the voltage of  $V_{IN}$  is higher than  $V_{OC2}$  and stays

longer than  $T_{OC2}$ , we consider the IC works in the state of discharge overcurrent 2; When the voltage of VIN is higher than  $V_{SHORT}$  and stays longer than  $T_{SHORT}$ , we think the IC works in the state of short circuit. When any of the three states occurs, the output voltage of DO changes to low level to turn off the discharge MOSFET and stop discharging. At the same time,  $R_{VMS}$  which is the inner pulling down resistance of VM is connected, and we know that VM is pad which we can lock the output voltage of DO by when chip works in the state of discharge overcurrent. Usually  $V_{OC1} < V_{OC2} < V_{SHORT}$ ,  $T_{OC1} > T_{OC2} > T_{SHORT}$ .

在放电时，放电电流随着负载而变化，VIN 电压随着放电电流的增大而增大。当 VIN 电压高于  $V_{OC1}$  并持续一段时间  $T_{OC1}$ ，即认为出现了过电流 1；当 VIN 电压高于  $V_{OC2}$  并持续  $T_{OC2}$ ，即认为出现了过电流 2；当 VIN 电压高于  $V_{SHORT}$  并持续  $T_{SHORT}$ ，即认为出现了短路。三种中任意一种状态出现后，DO 由高电平变为低电平，关断放电 MOS 管停止放电，同时，过流锁定端子 VM 端内部下拉电阻  $R_{VMS}$  接入。通常  $V_{OC1} < V_{OC2} < V_{SHORT}$ ， $T_{OC1} > T_{OC2} > T_{SHORT}$ 。

When IC works in discharge overcurrent, the output voltage of DO is locked in low level, it will be released when the following conditions occurs in the same time.

(1) disconnect the load;

(2)  $VM < 1V$  and stays a period of time  $T_{ROC1}$ .

过电流保护时 DO 被锁定为低电平，同时满足以下条件才可解除锁定：

(1) 断开负载；

(2)  $VM < 1V$  并持续  $T_{ROC1}$ 。

#### 4. Charge overcurrent / 充电过电流

During charging, if the current is biggish with  $VIN < V_{OVCC}$  and stays longer than  $T_{OVCC}$ , the BM3560 chip considers that the batteries work in the state of charge overcurrent, the output voltage of CO will be pulled down to low level and the charge MOSFET will be turned off and stop charging. Charge overcurrent protection will be released when we disconnect the charger.

在充电时，如果充电电流过大且  $VIN < V_{OVCC}$  并持续了一段时间  $T_{OVCC}$ ，芯片认为发生了充电过电流状态，CO 被外接电阻下拉至低电平，充电控制 MOS 管关断。若充电器一直存在，充电过流状态被锁定，只有将充电器移除才能解除。

#### 5. Temperature protection / 温度保护

Usually, batteries should be prevented charging and discharging from over or under temperature. The BM3560 chip has this over-temperature and under-temperature protection. The thermostat resistor connecting to NTC pad is used to induct the pack's temperature, the resistor connecting TRH pad is used to set the reference of over-temperature protection, and the resistor connecting TRL pad is used to set the reference of under-temperature protection. During temperature detecting, the BM3560 considers discharge state acquiescently when  $VIN < 4mV$ , only when  $VIN > 4mV$ , the BM3560 considers charge state. Choose the resistance of NTC that the value of B is 3950, NTC resistance is 100K $\Omega$  in normal temperature (25 $^{\circ}C$ ). NTC should parallel a 200K resistance in typical application, and it's better that the accuracy of TRH and TRL is 1%. Setting the charge over-temperature to 55 $^{\circ}C$ , the resistance of NTC is  $R_{NTC} = 29.56K$ , after 200K resistance in parallel,  $R1 = 200 * 29.56 / (200 + 29.56) = 25.75K$ , so we should choose  $R_{TRH} = 2 * R1 = 51.1K$ . We can figure out  $R1 = R_{TRH} * 1.3 / 5 = 13.3K$ , and the NTC resistance of discharge over-temperature  $R_{NTC} = 200 * 13.3 / (200 - 13.3) = 14.58K$ , correspond the discharge over-temperature is 75 $^{\circ}C$ . Setting the charge under-temperature to 0 $^{\circ}C$ , the resistance of NTC is  $R_{NTC} = 325.1K$ , after 200K resistance in parallel,  $R1 = 200 * 325.1 / (200 + 325.1) = 123.82K$ , so we should

choose  $R_{TRH}=25*R1/6=511K$ .

Setting the charge or discharge over-temperature protection by TRH, and setting the charge under-temperature protection by TRL, the temperature protection points can refer to next table.

为了防止充放电过程中电芯温度过高或过低给电芯带来的损坏，需要对电芯进行高低温保护。NTC 端子连接热敏电阻用于感应温度变化，TRH 端子连接电阻用于高温保护基准的设置，TRL 端子连接电阻用于低温保护基准的设置。当  $V_{IN} < 4mV$  时，芯片默认为充电状态检测。当  $V_{IN} > 4mV$  时，芯片识别为放电检测，NTC 选择 B 值为 3950 的 100K 电阻，典型应用时 NTC 电阻需并联一个 200K 电阻，TRH 和 TRL 选择 1%精度的电阻。设定充电保护温度为 55℃时，对应  $R_{NTC} = 29.56K$ ，并联 200K 电阻后，R1 阻值为 25.75K，则选取 TRH 电阻阻值为  $R_{TRH} = 2*R1=51.1K$ ，放电过温保护时对应 R1 电阻大小为  $R1 = R_{TRH}*0.22 = 13.3K$ ，则与 200K 电阻并联的 NTC 电阻大小为  $R_{NTC} = 14.58K$ ，对应温度为 75℃；设定充电低温保护温度为 0℃时，对应  $R_{NTC} = 325.1K$ ，并联 200K 电阻后，R1 阻值为 123.82K，则选取 TRL 电阻阻值为  $R_{TRL} = 25*R1/6 = 511K$ 。

通过 TRH 设置充、放电高温保护，通过 TRL 设置充电低温保护，各温度点参考如下表格：

The parallel resistance with NTC NTC 并联电阻大小	TRH setting TRH 设置电阻大小	Charge over-temperature 充电高温保护温度	Discharge over-temperature 放电高温保护温度	TRL setting TRL 设置电阻大小	Charge under-temperature 充电低温保护温度
200K	84.5K	40℃	60℃	464K	5℃
200K	71.5K	45℃	65℃	511K	0℃
200K	60.4K	50℃	70℃	562K	-5℃
200K	51.1K	55℃	75℃	604K	-10℃
200K	43.2K	60℃	80℃	681K	-20℃

The hysteresis temperature of charge over-temperature is 5℃ and the hysteresis temperature of discharge over-temperature is 10℃. For example, when the temperature is higher than charge over-temperature (55℃) in the state of charging, the output voltage of CO turns to high resistance, and will be pulled down to low level by external resistor, charge control MOSFET will be turned off and stops charging. And when the pack's temperature falls down to 50℃, CO changes to high level and charge control MOSFET be turned on again. During discharging, when the temperature is higher than discharge over-temperature (75℃), the output voltage of DO becomes low level, discharge control MOSFET will be turned off and stop discharging, at the same time charge control MOSFET will also be turned off and stops charging. When pack's temperature falls down to 65℃, the output of CO and DO turn to high level, charge and discharge control MOSFET will both be turned on again.

充电高温保护迟滞为 5℃，放电高温保护迟滞为 10℃。例如，充电状态时当温度达到充电高温保护温度 55℃，CO 变为高阻态，由外接电阻下拉至低电平，充电 MOS 管关断并停止充电，当电芯温度降到 50℃ 时，CO 变为高电平，充电控制 MOS 重新开启。放电状态时当温度达到放电高温保护温度 75℃，DO 变为低电平，放电 MOS 管关断并停止放电，同时将充电 MOS 管也关断并禁止充电，当电芯温度降到 65℃ 时，DO、CO 变为高电平，充、放电 MOS 重新开启。

The hysteresis temperature of charge under-temperature is 5℃. For instance, during charging, when the temperature is lower than charge under-temperature (-10℃), the output voltage of CO becomes low level, and will be pulled down to low level by external resistor, charge control MOSFET will be turned off and stop charging. When pack's temperature rise to -5℃, the output of CO turn to high level,

charge control MOSFET will be turned on again. There is no under-temperature protection when pack is discharging, so even if the temperature is lower than  $-10^{\circ}\text{C}$ , the output of CO still maintain high level.

充电低温保护迟滞为  $5^{\circ}\text{C}$ 。例如，充电状态时当温度低于充电低温保护温度  $-10^{\circ}\text{C}$ ，CO 变为高阻态，由外接电阻下拉至低电平，充电 MOS 管关断并停止充电，当电芯温度升至  $-5^{\circ}\text{C}$  时，CO 变为高电平，充电控制 MOS 重新开启。放电状态时无低温保护，即使低于充电低温保护温度，CO 不关断，维持正常状态。

### 6. Breaking wire protection /断线保护

When one or multi wires of VC1, VC2, VC3, VC4, VC5 and VC6 are detected cut from the batteries by the BM3560 chip, the IC will consider it enters a state of breaking wire, then CO will be in high resistance and DO will turn to GND level the IC enters low consumption state.

The IC enters low consumption state and when the breaking wires are connected correctly again, the IC will exit breaking wire protection.

Specially attention, regardless one chip application or multi-chip application, the GND pin must not be open from the battery, or the IC cannot operate normally, and it cannot protect correctly.

当芯片检测到管脚 VC1、VC2、VC3、VC4、VC5、VC6 中任意一根或多根与电芯的连线断开，芯片判断为发生了断线，即将 CO 输出高阻态，DO 输出低电平，此保护状态称为断线保护状态。

断线保护后，芯片进入低功耗。当断开的连线重新正确连接后，芯片退出断线保护状态。

特别注意，单芯片应用与级联应用时，均不可将芯片引脚 GND 与电芯的连线断开，若断开，芯片无法正常工作，无法进入断线保护。

### 7. Delay time setting /延时设置

Over-discharge, discharge overcurrent 1 and 2 delay time can be calculated as follow (unit: s)

过放电延时，过流 1 和过流 2 延时参考下表设置，延时与  $C_{TD}$  所接电容大小成比例：

$C_{TD}=0.1\mu\text{F}$	延时项目 Delay time Item	TC 引脚悬空 TC floating	TC 引脚与 TD 引脚连接 TC connect to TD
	$T_{OVD}$	1000ms	1000ms
$T_{OC1}$	1000ms	250ms	
$T_{OC2}$	100ms	80ms	
$C_{TD}=0.01\mu\text{F}$	延时项目 Delay time Item	TC 引脚悬空 TC floating	TC 引脚与 TD 引脚连接 TC connect to TD
	$T_{OVD}$	100ms	100ms
$T_{OC1}$	100ms	25ms	
$T_{OC2}$	10ms	8ms	

**Caution:** The formula above does not include capacitance error, it is recommend to select a higher accuracy capacitance within  $\pm 5\%$ .

**注意：**上述公式不包括电容器精度误差， $C_{TD}$  电容建议选择精度  $\pm 5\%$  规格。

### 8. Extended application /级联功能

级联应用方案时，各 IC 均可将自身的过充电、过放电、传输给下一级 IC。上一级 DO 由高电平转变为低电平时，下级芯片的 DOIN 接收信号，关闭 DO 控制 MOS。

同理 COIN 接收上一级的信号，关闭 CO 控制 MOS。DOIN、COIN 优先于内部保护电路。

DOIN 输入电压	COIN 输入电压	DO/CO 输出电压
VDD	VDD	Normal state
VSS	VSS	低电平

## Operation Timing Charts /工作时序图

### 1. Overcharge/Over-discharge Protection 过充电、过放电保护

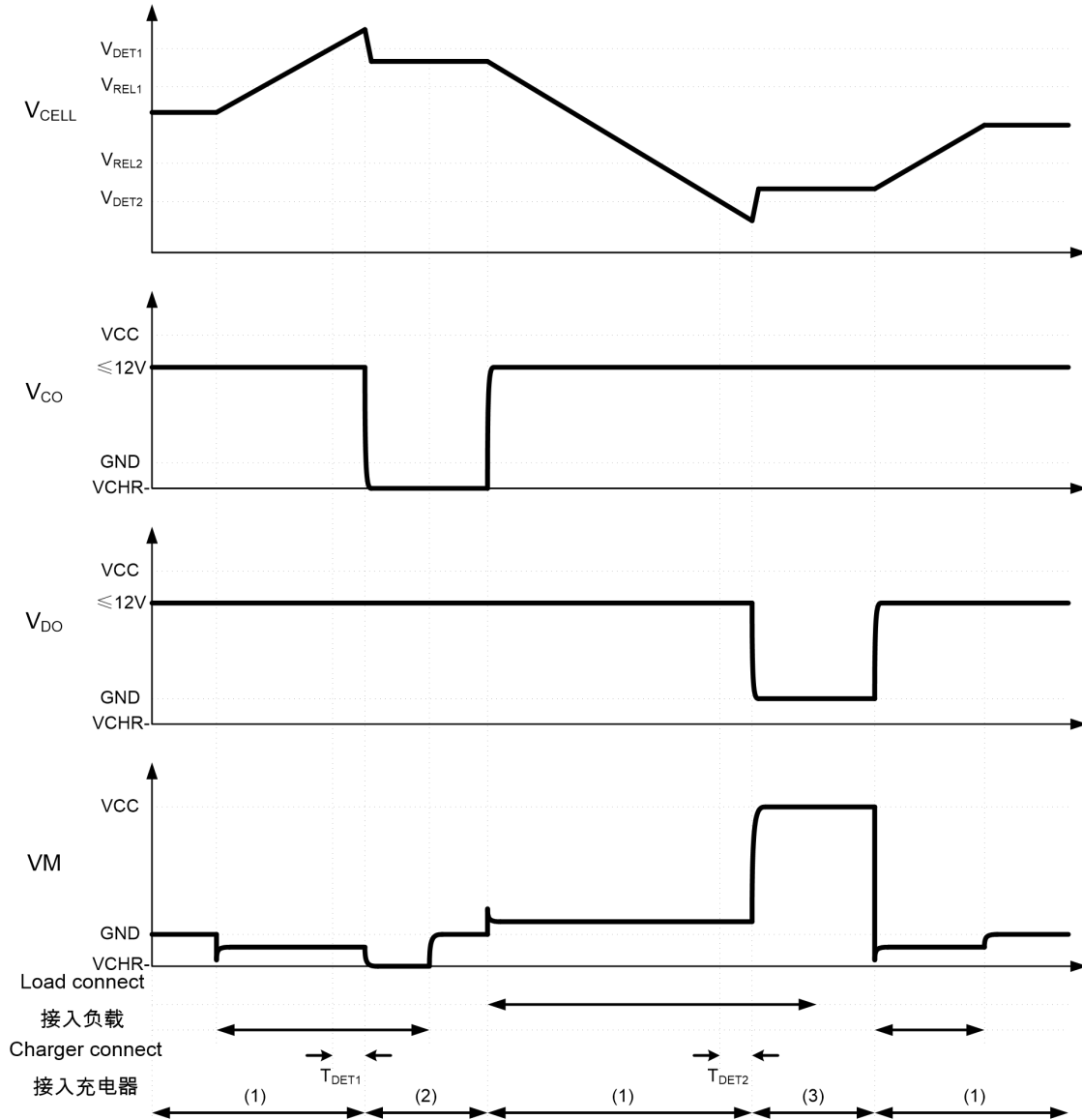

Assuming the charging current is constant,  $V_{CHR-}$  is the voltage of the charger's negative terminal:  
假定为恒流充电,  $V_{CHR-}$ 为充电器空载时负端电压:

- (1) Normal condition /通常状态;
- (2) Overcharge protection state /过充电保护状态;
- (3) Over-discharge protection state /过放电保护状态。

2. Discharge Overcurrent / Short Circuit / Charge Overcurrent Protection  
放电过电流、短路、充电过电流保护

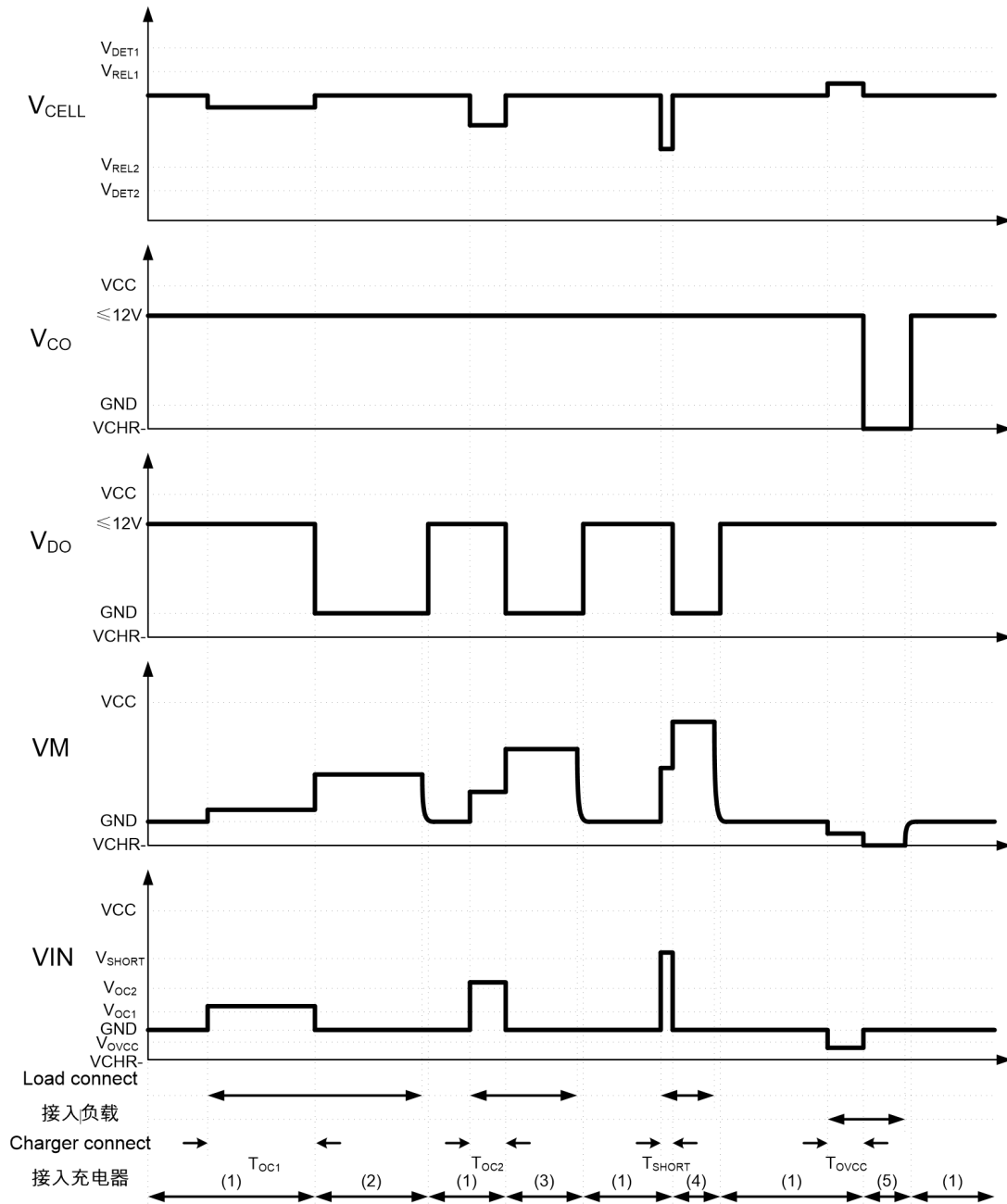

Assuming the charging current is constant, VCHR- is the voltage of the charger's negative terminal:  
假定为恒流充电，VCHR-为充电器空载时负端电压：

- (1) Normal condition /通常状态；
- (2) Discharge overcurrent 1 protection state /放电过电流 1 保护状态；
- (3) Discharge overcurrent 2 protection state /放电过电流 2 保护状态；
- (4) Short circuit protection state /短路保护状态；
- (5) Charge overcurrent protection state /充电过电流保护状态。

Application Circuits /应用电路

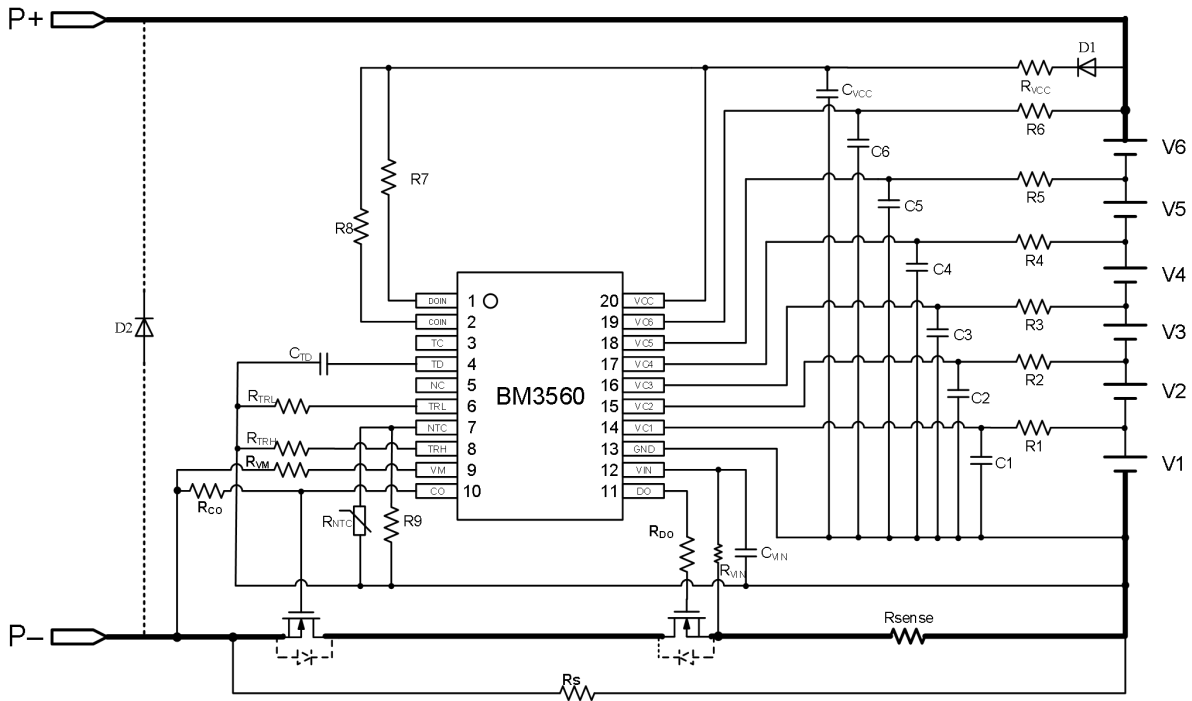

6-cell application -- charge and discharge circuits together

6 串典型应用——充放电同口

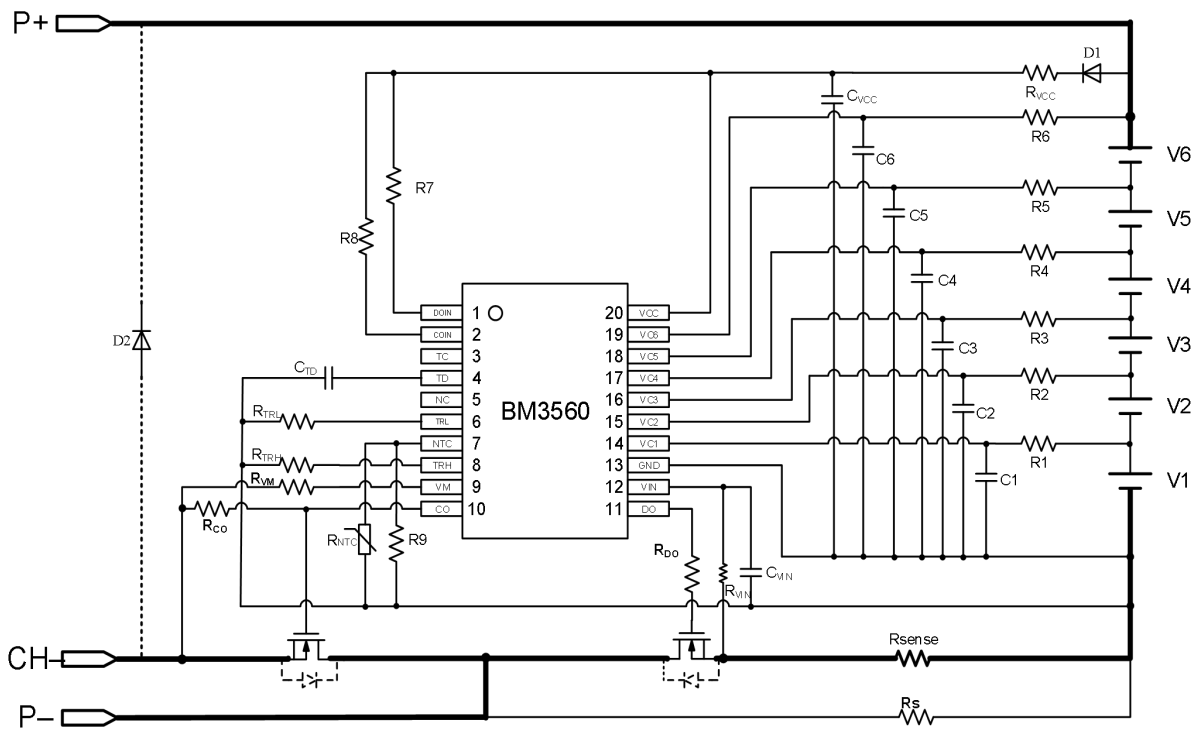

6-cell application -- charge and discharge circuits separated

6 串典型应用——充放电分口



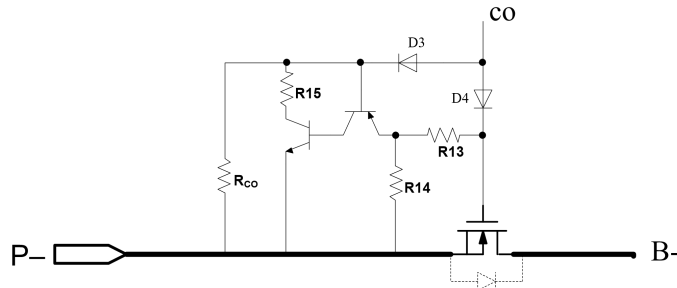

To speed up the response of charge MOSFET, we recommend to add a fast pull-down circuit to CO pin.  
为加快 CO 端 MOS 管的响应速率，推荐添加 CO 端快速下拉电路

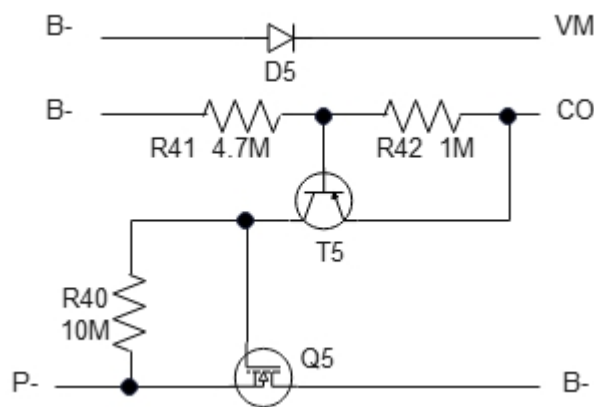

It is recommended when the charge voltage is 20V higher than the total battery voltage.  
当充电器电压比电池总电压高 20V 时推荐使用

Constants for External Components:

电阻、电容推荐值如下：

Component Symbol 器件标号	Typ. 典型值	Range 范围	Unit 单位
R1、R2、R3、R4、R5、R6	1	0.1 ~ 2	KΩ
R <sub>VCC</sub> 、R13	1	0.1 ~ 2	KΩ
R7、R8	200	100 ~ 1000	KΩ
R15	100	-	kΩ
R <sub>NTC</sub>	100	-	KΩ
R9	200	-	KΩ
R <sub>TRH</sub>	51.1	-	KΩ
R <sub>TRL</sub>	511	-	KΩ
R <sub>VM</sub>	511	-	KΩ
R14、R <sub>CO</sub>	10	3.3~15	MΩ
R <sub>S</sub>	2	1~10	MΩ
R <sub>DO</sub> 、R <sub>VIN</sub>	2	0~10	KΩ
R <sub>sense</sub>	5	1 ~ 20	mΩ

$C_{VCC}$	2.2	1 ~ 4.7		$\mu F$
C1、C2、C3、C4、C5、C6	0.1	0.1~2.2	Maximum endurable voltage >50V	$\mu F$
$C_{TD}$	0.1	-		$\mu F$
$C_{VIN}$	10	2.2~100		nF

备注： $R_S = 2 M\Omega$ 时，过放保护后断负载 DO 可自恢复； $R_S = 10 M\Omega$ 时，过放保护后断负载需接充电器激活。

## Test circuit /测试电路

### 1. Normal and Sleeping Current Consumption /正常功耗及休眠功耗

Test circuit 1 /测试电路 1

- Set  $V1 = V2 = V3 = V4 = V5 = V6 = 3.5V$ , the current flowing from GND is the normal operating current consumption.  
设定  $V1 = V2 = V3 = V4 = V5 = V6 = 3.5V$ ，观察电流表的读数，流出 GND 的电流即正常功耗。
- On the condition of (1), then set  $V1 = V2 = V3 = V4 = V5 = V6 = 2.0V$ , the current flowing from GND is the sleeping current consumption.  
在(1)的基础上，设定  $V1 = V2 = V3 = V4 = V5 = V6 = 2.0V$ ，观察电流表的读数，流出 GND 的电流即休眠功耗。

### 2. Overcharge Protection Test /过充电测试

Test circuit 2 /测试电路 2

#### 2.1 Overcharge threshold ( $V_{DET1}$ ) and Overcharge release threshold ( $V_{REL1}$ )

过充电保护及保护解除阈值

Set  $V1 = V2 = V3 = V4 = V5 = V6 = 3.5V$ , make sure the output voltages of DO and CO pins are "H" level. Increase  $V6$  gradually, monitor CO voltage and keep the condition not shorter than  $T_{DET1}$ , the value of  $V6$  when CO turns from "H" to "L" is the overcharge threshold voltage. Decrease  $V6$  and keep the condition not shorter than  $T_{REL1}$ , the  $V6$  is the overcharge release threshold when CO returns to "H" level again.

设定  $V1 = V2 = V3 = V4 = V5 = V6 = 3.5V$ ，确保 DO、CO 都为"H"。逐渐增大  $V6$ ，维持时间不小于过充电保护延时，当 CO 由"H"变"L"时的  $V6$  电压即为过充电保护阈值电压 ( $V_{DET1}$ )；逐渐减小  $V6$ ，维持时间不小于过充电保护解除延时，当 CO 重新变为"H"时， $V6$  电压即为过充电保护解除阈值电压 ( $V_{REL1}$ )。

#### 2.2 Overcharge protection delay time and Overcharge release delay time

过充电保护及过充电回复延时

- Set  $V1 = V2 = V3 = V4 = V5 = V6 = 3.5V$  make sure the output voltages of DO and CO pins are "H" level. Increase  $V6$  to 4.4V from 3.5V instantaneously, monitor CO voltage and keep a period of time. The time interval when CO turns from "H" to "L" is the overcharge protection delay time.  
设定  $V1 = V2 = V3 = V4 = V5 = V6 = 3.5V$ ，确保 DO、CO 都为"H"。将  $V6$  骤升至 4.4V，监控 CO 电压并维持一段时间，CO 由"H"变"L"的时间间隔即为过充电延时。
- Set  $V1 = V2 = V3 = V4 = V5 = 3.5V$ ,  $V6 = 4.4V$ , make sure the output voltage of DO is "H" level, CO is "L" level. Decrease  $V6$  to 3.5V from 4.4V instantaneously, monitor CO voltage and keep a period of time. The time interval when the output voltage of CO turns from "L" to "H" is the overcharge release delay time.  
设定  $V1 = V2 = V3 = V4 = V5 = 3.5V$ ,  $V6 = 4.4V$ ，确保 DO 为"H"，CO 为"L"。将  $V6$  骤降至 3.5V，监控 CO 电压并维持一段时间，CO 由"L"变"H"的时间间隔即为过充电回复延时。

### 3. Over-discharge Protection Test /过放电测试

Test circuit 2 /测试电路 2

#### 3.1 Over-discharge threshold ( $V_{DET2}$ ) and Over-discharge release threshold ( $V_{REL2}$ )

过放电保护及过放电保护解除阈值

Set  $V1 = V2 = V3 = V4 = V5 = V6 = 3.5V$ , make sure the output voltages of DO and CO pins are “H” level. Decrease  $V6$  gradually, monitor DO voltage and keep the condition not shorter than  $T_{DET2}$ , the value of  $V6$  when the output voltage of DO turns from “H” to “L” is the over-discharge threshold voltage. Increase  $V6$  and keep the condition not shorter than  $T_{REL2}$ , the value of  $V6$  when DO returns to “H” level again is the over-discharge release threshold.

设定  $V1 = V2 = V3 = V4 = V5 = V6 = 3.5V$ ，确保 DO、CO 都为“H”。逐渐减小  $V6$ ，维持时间不小于过放电保护延时，当 DO 由“H”变为“L”时的  $V6$  电压即为过放电保护阈值电压 ( $V_{DET2}$ )；逐渐增大  $V6$ ，维持时间不小于过放电保护解除延时，当 DO 重新变为“H”时， $V6$  电压即为过放电保护解除电压 ( $V_{REL2}$ )。

#### 3.2 Over-discharge protection delay time and Over-discharge release delay time

过放及过放回复延时

- (1) Set  $V1 = V2 = V3 = V4 = V5 = V6 = 3.5V$ , make sure the output voltages of DO and CO pins are “H” level. Decrease  $V6$  to 2.0V instantaneously, monitor DO voltage and keep a period of time. The time interval is the over-discharge protection delay time when DO turns from “H” to “L”.

设定  $V1 = V2 = V3 = V4 = V5 = V6 = 3.5V$ ，确保 DO、CO 都为“H”。将  $V6$  骤降至 2.0V，监控 DO 电压并维持一段时间，DO 由“H”变为“L”的时间间隔即为过放电延时。

- (2) Set  $V1 = V2 = V3 = V4 = V5 = 3.5V$ ,  $V6 = 2.0V$ , make sure CO is “H” level, DO is “L” level. Increase  $V6$  to 3.5V instantaneously, monitor DO voltage and keep a period of time. The time interval when the output voltage of DO turns from “L” to “H” is the overcharge release delay time.

设  $V1 = V2 = V3 = V4 = V5 = 3.5V$ ， $V6 = 2.0V$ ，确保 DO 为“L”，CO 为“H”。将  $V6$  骤升至 3.5V，监控 DO 电压并维持一段时间，DO 由“L”变为“H”的时间间隔即为过放电回复延时。

### 4. Discharge overcurrent and short circuit protection test /放电过电流及短路测试

Test circuit 3 /测试电路 3

#### 4.1 Discharge overcurrent 1 and 2 threshold ( $V_{DET3}$ , $V_{DET4}$ ) and short circuit threshold ( $V_{SHORT}$ )

过电流及短路保护阈值

Set  $V1 = V2 = V3 = V4 = V5 = V6 = 3.5V$ ,  $V7 = 0V$ , make sure the output voltages of DO and CO pins are “H” level. Increase  $V7$  gradually, monitor DO voltage and keep the condition for a period of time, the value of  $V7$  when the output voltage of DO turns from “H” to “L”, is the discharge overcurrent 1 threshold ( $V_{DET3}$ ). Decrease  $V7$ , the discharge overcurrent 1 protection will be released.  $V_{DET4}$  and  $V_{SHORT}$  can also be tested by their protection time differences, but  $V7$  has a larger change.

设定  $V1 = V2 = V3 = V4 = V5 = V6 = 3.5V$ ， $V7 = 0V$ ，确保 DO、CO 都为“H”。逐渐增大  $V7$ ，维持时间不小于过电流 1 保护延时，当 DO 由“H”变为“L”时的  $V7$  电压即为过电流 1 保护阈值 ( $V_{DET3}$ )。过电流 2 阈值 ( $V_{DET4}$ ) 及短路阈值 ( $V_{SHORT}$ ) 的测试需同时根据设定的保护延时长短去判断。

#### 4.2 Discharge overcurrent protection delay time and release delay time

过电流及过电流回复延时

- (1) Set  $V1 = V2 = V3 = V4 = V5 = V6 = 3.5V$ ,  $V7 = 0V$ ,  $V11 = 0V$ , make sure the output voltages of DO and CO pins are “H”. Increase  $V7$  to 0.2V instantaneously, monitor DO voltage and keep a period of time. The time interval when the output voltage of DO turns from “H” to “L” is the discharge overcurrent 1 protection delay time.

设定  $V1 = V2 = V3 = V4 = V5 = V6 = 3.5V$ ,  $V7 = 0V$ ,  $V11 = 0V$ , 确保 DO、CO 都为“H”。将 V7 骤然增大至 0.2V, 监控 DO 电压并维持一段时间, DO 由“H”变为“L”的时间间隔即为过电流 1 延时。

- (2) Set  $V1 = V2 = V3 = V4 = V5 = V6 = 3.5V$ ,  $V7 = 0V$ ,  $V11 = 0V$ , make sure the output voltages of DO and CO pins are “H”. Increase V7 instantaneously with its value be larger, monitor DO voltage and keep a period of time. The time interval when the output voltage of DO turns from “H” to “L” is the discharge overcurrent 2 protection delay time, make sure its value is less than the discharge overcurrent 1 protection delay time, then the value of V7 at this time is the discharge overcurrent 2 threshold.

设定  $V1 = V2 = V3 = V4 = V5 = V6 = 3.5V$ ,  $V7 = 0V$ ,  $V11 = 0V$ , 确保 DO、CO 都为“H”。逐步将 V7 骤然增大, 即每次增大至的 V7 电压值比前一次大, 同时监测 DO 由“H”变为“L”的延时, 监测到的第一个比过电流 1 短的延时对应的 V7 的电压即为过电流 2 阈值, 这个延时即为过电流 2 延时。

- (3) Set  $V1 = V2 = V3 = V4 = V5 = V6 = 3.5V$ ,  $V7 = 0V$ ,  $V11 = 0V$ , make sure the voltages of DO and CO pins are “H”. Increase V7 instantaneously with its value larger and larger, monitor DO voltage and keep a period of time. The time interval when DO turns from “H” to “L” is the short circuit protection delay time, make sure its value is less than the discharge overcurrent 2 protection delay time, and the value of V7 at this time is the short circuit threshold.

设定  $V1 = V2 = V3 = V4 = V5 = V6 = 3.5V$ ,  $V7 = 0V$ ,  $V11 = 0V$ , 确保 DO、CO 都为“H”。逐步将 V7 骤然增大, 即每次增大至的 V7 电压值比前一次大, 同时监测 DO 由“H”变为“L”的延时, 监测到的第一个比过电流 2 短的延时对应的 V7 的电压即为短路阈值, 这个延时即为短路延时。

- (4) Set  $V1 = V2 = V3 = V4 = V5 = V6 = 3.5V$ ,  $V7 = 0.2V$ ,  $V11 = 10V$ , make sure the output voltage of DO pin and CO pin is “L” and “H”. Decrease V7 to 0V instantaneously, and then decrease V11 to 0V instantaneously, monitor DO voltage and last a period of time. The time interval when DO turns from “L” to “H” is the discharge overcurrent 1 release delay time, we can test the release delay time of discharge overcurrent 2 and short circuit by using the same method.

设定  $V1 = V2 = V3 = V4 = V5 = V6 = 3.5V$ ,  $V7 = 0.2V$ ,  $V11 = 10V$ , 确保 DO 为“L”, CO 为“H”。将 V7 骤然降至 0V 后, V11 骤然降至 0V, 监控 DO 电压并维持一段时间, DO 由“L”变为“H”的时间间隔即为过电流 1 回复延时。同样的测试方法可以测出过电流 2 回复延时及短路回复延时。

## 5. Charge overcurrent protection test / 充电过电流测试

Test circuit 4 / 测试电路 4

### 5.1 Charge overcurrent protection threshold / 充电过电流保护阈值

Set  $V1 = V2 = V3 = V4 = V5 = V6 = 3.5V$ ,  $V8 = 0V$ , make sure the output voltages of DO and CO pins are “H”. Increase V8 gradually, monitor CO voltage and keep a period of time. The value of V8 when the output voltage of CO turns from “H” to “L” is the charge overcurrent threshold.

设定  $V1 = V2 = V3 = V4 = V5 = V6 = 3.5V$ ,  $V8 = 0V$ , 确保 DO、CO 都为“H”。逐渐增大 V8, 维持时间不小于充电过电流保护延时, Co 由“H”变为“L”时 V8 即为充电过电流保护阈值。

### 5.2 Charge overcurrent protection delay time / 充电过电流保护延时

Set  $V1 = V2 = V3 = V4 = V5 = V6 = 3.5V$ ,  $V8 = 0V$ , make sure the output voltages of DO and CO pins are “H”. Increase V8 to 0.3V instantaneously, monitor the CO voltage and keep a period of time. The time interval when the output voltage of CO pin turns from “H” to “L” is the charge overcurrent protection delay time.

设定  $V1 = V2 = V3 = V4 = V5 = V6 = 3.5V$ ,  $V8 = 0V$ , 确保 DO、CO 都为“H”。将 V8 骤然增大至 0.3V, 监控 CO 电压并维持一段时间, CO 由“H”变为“L”的时间间隔即为充电过电流保护延时。

## 6. Output/Input Resistance Test /输入/输出电阻测试

### (1) The output resistances of CO and DO

CO、DO 为高电平时的输出电阻

Test circuit 5 /测试电路 5

Set  $V_1 = V_2 = V_3 = V_4 = V_5 = V_6 = 3.5V$ ,  $V_9 = 0.00V$ , turn off the switch K and make sure the output voltage of CO pin is "H". Measure the voltage  $V_A$  of CO pin; turn on the switch K, decrease the voltage  $V_9$  gradually from 12V, monitor the value of  $I_A$ , and note down the output voltage  $V_B$  of CO pin when the value of  $I_A$  is 50uA, then the output resistance of CO is calculated as follows:  $R_{COH} = (V_A - V_B)/50$  (M $\Omega$ ).

We can also test the output resistance  $R_{DOH}$  of DO pin with using the same method.

设定  $V_1 = V_2 = V_3 = V_4 = V_5 = V_6 = 3.5V$ ,  $V_9 = 0V$ , 开关 K 断开, 确保此时 CO 输出为"H", 测量 CO 端的电压  $V_A$ ; 闭合开关 K,  $V_9$  从 12V 开始降低, 监测电流表的读数为  $I_A$ , 当  $I_A = 50\mu A$  时测得 CO 端的电压  $V_B$ , 则 CO 输出电阻  $R_{COH} = (V_A - V_B)/50$  (M $\Omega$ )。

同样的测试方法可用于测试 DO 输出电阻  $R_{DOH}$ , 只需将测试端子改为 DO 即可。

### (2) The output resistance when the output voltage of DO pin is "L"

DO 为低电平时的输出电阻

Test circuit6 /测试电路 6

Set  $V_1 = V_2 = V_3 = V_4 = V_5 = V_6 = 2.00V$ ,  $V_{10} = 0.00V$ , turn off the switch K and make sure the output voltage of DO pin is "L". Turn on the switch K, increase the voltage  $V_{10}$  gradually from 0V, monitor the value of  $I_A$ , note down the output voltage  $V_{DO}$  of DO pin when the value of  $I_A$  is 50uA, then the output resistance of DO is calculated as follows:  $R_{DOL} = V_{DO}/50$  (M $\Omega$ ).

设定  $V_1 = V_2 = V_3 = V_4 = V_5 = V_6 = 2.00V$ ,  $V_{10} = 0.00V$ , 开关 K 断开, 用电压表测试 DO 端电压, 确保此时 DO 输出为 0V。将开关 K 闭合, 调节  $V_{10}$  从 0V 开始上升, 同时监测电流表的读数为  $I_A$ , 当  $I_A = -50\mu A$  时测得 DO 电位为  $V_{DO}$ , 则 DO 输出电阻  $R_{DOL} = V_{DO}/50$  (M $\Omega$ )。

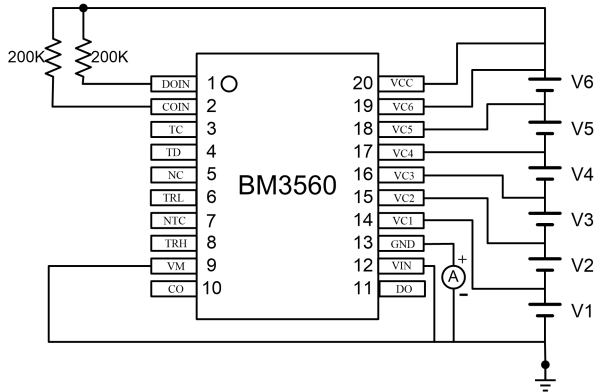

Test circuit 1  
测试电路 1

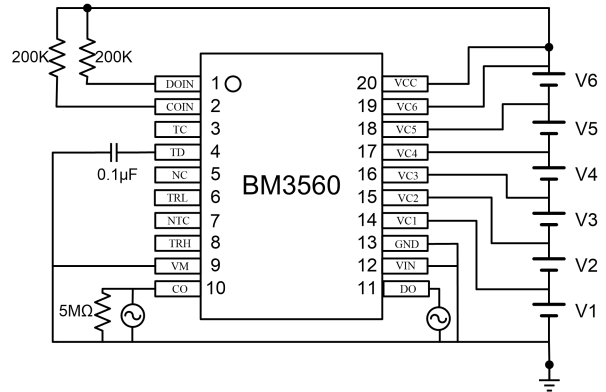

Test circuit 2  
测试电路 2

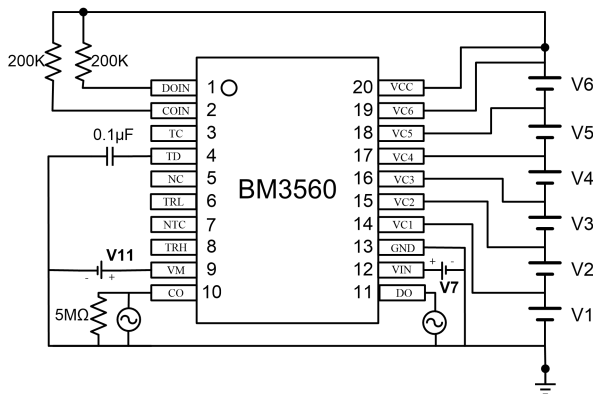

Test circuit 3  
测试电路 3

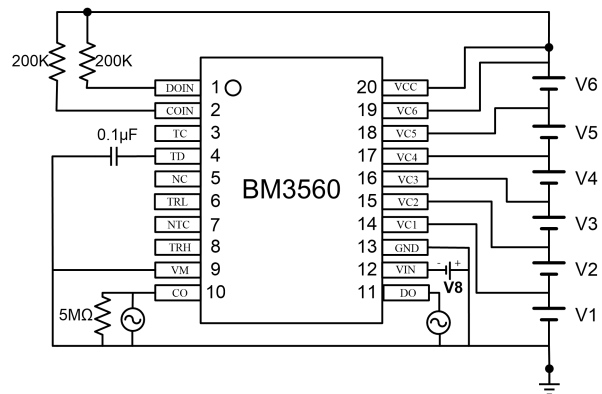

Test circuit 4  
测试电路 4

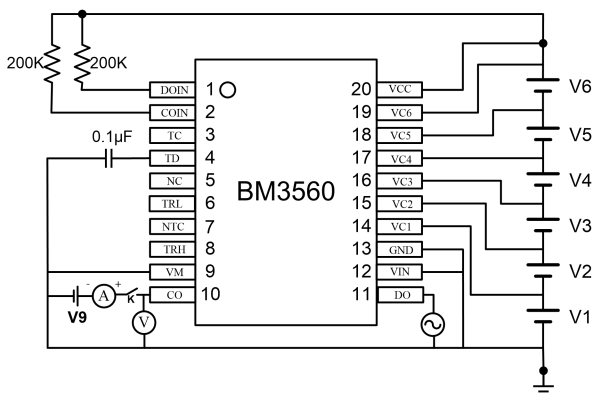

Test circuit 5  
测试电路 5

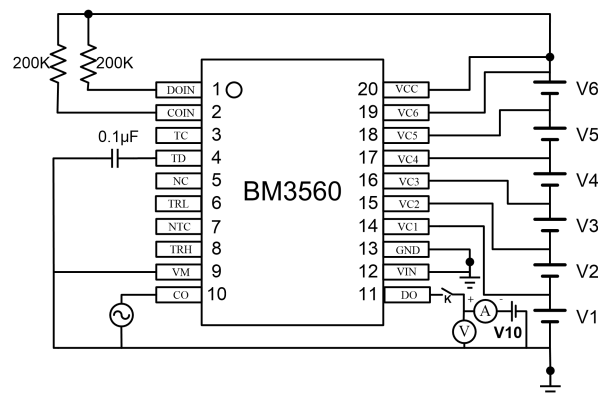

Test circuit 6  
测试电路 6

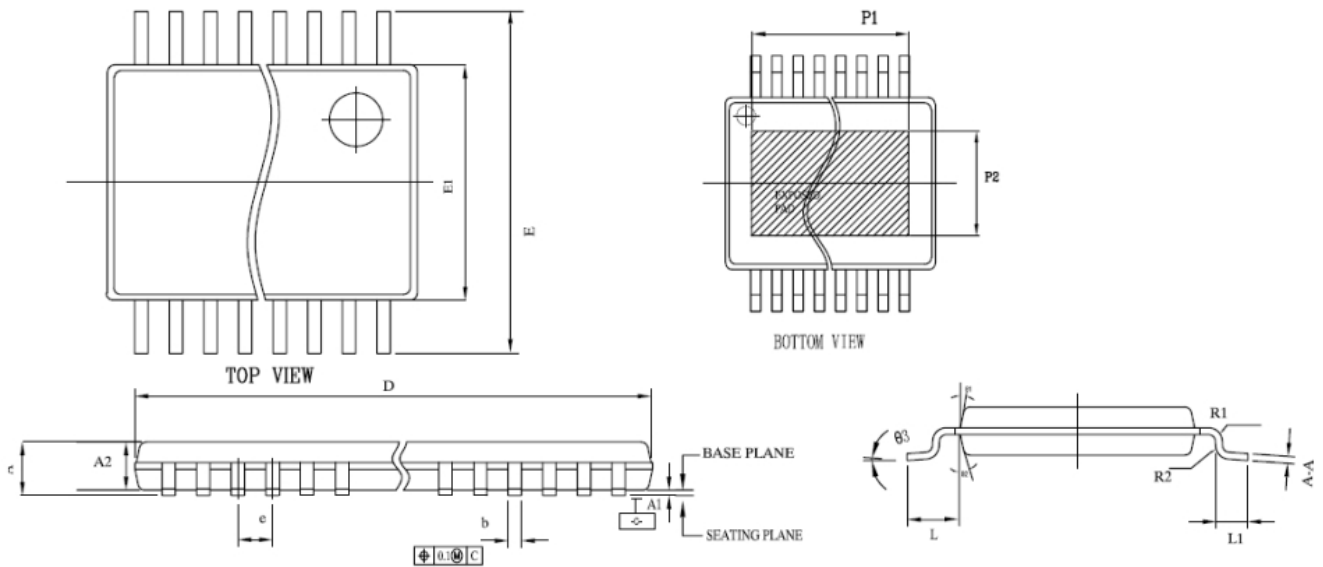
**Package Information / 封装示意图及参数**
**TSSOP20**

Symbol	符号	TSSOP20	
		Min	Max
A	总高		1.2
A1	站高	0.05	0.15
A2	塑封体高	0.8	1.05
E	跨度	6.25	6.55
E1	塑封体宽	4.3	4.5
D	塑封体长	6.4	6.6
L	脚长		1
L1		0.45	0.75
e	脚间距	0.65	
b	脚宽	0.19	0.3
R1		0.15TYP	
R2		0.15TYP	
A-A		0.09	0.2
θ 1	脱模斜度	12° TYP	
θ 2	脱模斜度	12° TYP	
θ 3	引脚角度	0	8

**Packing / 包装:**

TSSOP20: MBB packing, 13" reel, 4000pcs per reel.

TSSOP20 封装形式: 13 寸的 MBB 静电袋, 每盘装 4000 颗。

**RESTRICTIONS ON PRODUCT USE/产品使用须知**

- The information contained herein is subject to change without notice.
- BYD Semiconductor Company Limited exerts the greatest possible effort to ensure high quality and reliability. Nevertheless, semiconductor devices in general can malfunction or fail due to their inherent electrical sensitivity and vulnerability to physical stress. It is the responsibility of the buyer, when utilizing products, to comply with the standards of safety in making a safe design for the entire system, including redundancy, fire-prevention measures, and malfunction prevention, to prevent any accidents, fires, or community damage that may ensue. In developing your designs, please ensure that products are used within specified operating ranges as set forth in the most recent products specifications.
- The products listed in this document are intended for usage in general electronics applications (computer, personal equipment, office equipment, measuring equipment, industrial robotics, domestic appliances, etc.). These products are neither intended nor warranted for usage in equipment that requires extraordinarily high quality and/or reliability or a malfunction or failure of which may cause loss of human life or bodily injury (“Unintended Usage”). Unintended Usage include atomic energy control instruments, airplane or spaceship instruments, transportation instruments, traffic signal instruments, combustion control instruments, medical instruments, all types of safety devices, etc.. Unintended Usage of products listed in this document shall be made at the customer’s own risk.
- 本资料内容，随产品的改进，可能会有未经预告之修改，本公司拥有优先修改权。
- 比亚迪半导体股份有限公司一向致力于提高产品质量和可靠性，但是半导体产品有可能按某种概率发生故障或错误工作，为防止因故障或错误工作而产生人身事故，火灾事故，社会性损害等，请充分留意冗余设计、火灾蔓延对策设计、防止错误动作设计等安全。
- 本文所列比亚迪产品仅可应用于计算机、个人设备、办公设备、测量设备、工业机器人臂、家用电器等通用电气设备中、不可用于对精度、可靠性要求本极高的设备中，也不可应用于会造成人身伤亡的设备中，不可用设备包括但不限于原子能控制器、航空航天设备、医疗设备与其它安环设备，对产品不恰当的使用将由使用者承担可能存在的风险。